

snorkel

TL49J



CE

PARTS & SERVICE MANUAL

Part Number: 513868-200

March 2013

Serial Number TL49-01-008562 and after.

TL49J

ENGLISH

When contacting Snorkel for service or parts information, be sure to include the MODEL and SERIAL NUMBERS from the equipment nameplate. Should the nameplate be missing, the SERIAL NUMBER is also stamped on top of the chassis behind the toe hitch.

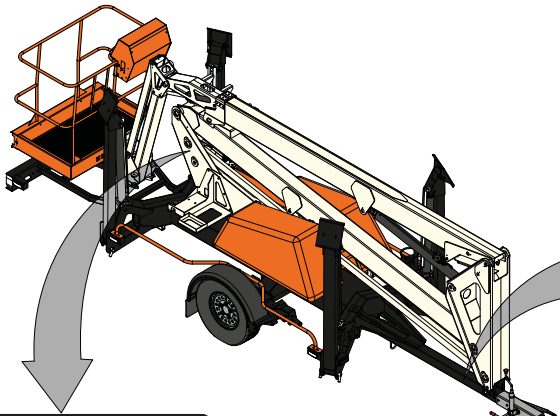

MANUFACTURER	TANFIELD POWERED ACCESS LTD.	Snorkel POWERED ACCESS
TYPE APPROVAL	e11*2007/46/0879	TANFIELD POWERED ACCESS LTD. WOOD CENTRE, BIRLEY ROAD, MIDDLETOWN, TYNE & WEAR, U.K. E 144 6544 100 007 www.snorkellifts.com
VIN		TYPE
MAX GROSS WT		Kg
MAX AXLE WT	0 -	Kg
	1 -	Kg
		VARIANT
		SER NR
		YEAR
		PART No: 508845-004

snorkel		CE	
MODEL NUMBER	TL49J BI ENERGY	SERIAL NUMBER	
MONTH / YEAR OF MANUFACTURE		SLOPE SENSOR ALARM SETTING	
NON-LOADED MACHINE WEIGHT	2300 lbs	FRONT to REAR	N/A deg 10 deg N/A deg
ENGINE POWERED MODELS	N/A hp	MAXIMUM WHEEL LOAD	N/A lbs
MAXIMUM OUTRIGGER LOAD	1320 lbs	BATTERY POWERED MODELS	N/A V
MAXIMUM GRADEABILITY	N/A %	BATTERIES	24 V 310 Ah
MAXIMUM ALLOWABLE MANUAL FORCE (SIDE FULL)	400 / 400 lbs	CHARGER INPUT	110/220 V
MAXIMUM PLATFORM HEIGHT	15.0 m	MAXIMUM ALLOWABLE WIND SPEED	12.5 mph
DATED NUMBER OF OCCUPANTS	2 / 2	MAXIMUM PLATFORM REACH	9.10 m
ASSEMBLED IN		MAXIMUM DRIVE HEIGHT	N/A m
CAUTION <small>ONLY trained and authorized personnel may operate this machine. Consult the Operation Manual before using this machine. Do NOT make any changes to this machine, and changes made will void the manufacturer's warranty and may be illegal.</small>			
<small>Asse weights with machine in the stowed position.</small>			
STEER AXLE	100 lbs	100 kg	
DRIVE AXLE	2200 lbs	2200 kg	

Serial number stamped on chassis behind the toe hitch and above the Vehical Identification Number Plate.

SAFETY NOTICE

Harness attachment points are provided in the platform and the manufacturer recommends the usage of a fall restraint harness, especially where required by national safety regulations.

All harness attachment points on SNORKEL vehicles have been tested with a force of 3,650 lbs (16.3 KN) per person.

See below examples of harness attachment points used on SNORKEL vehicles with their corresponding rating;

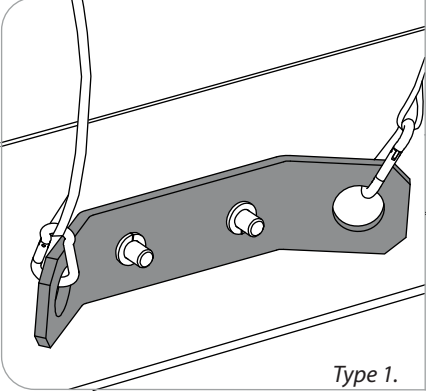
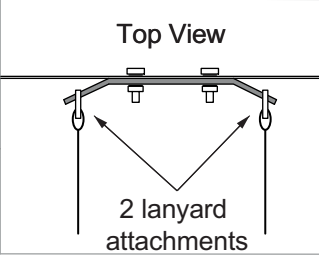
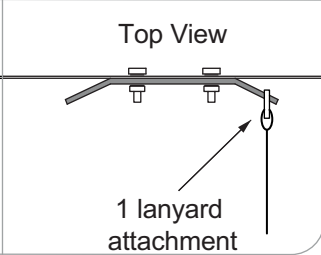
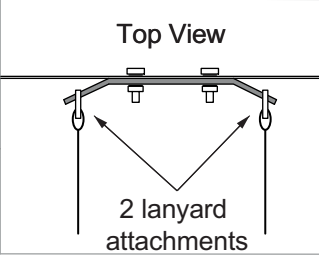
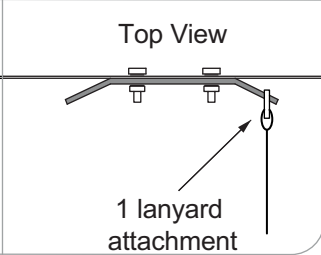
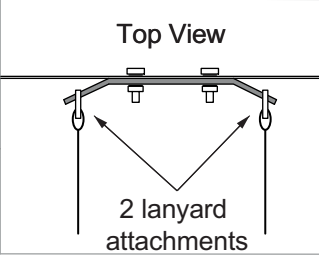
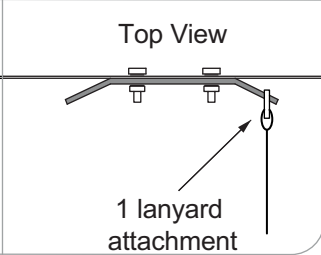
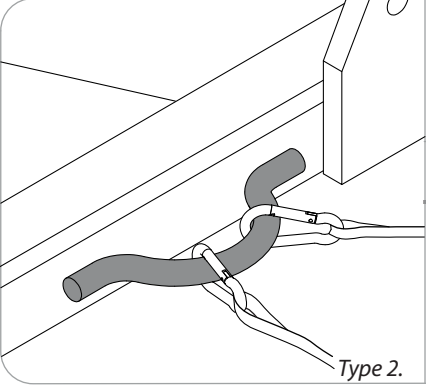
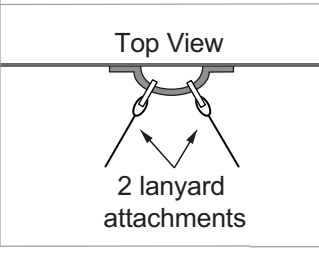
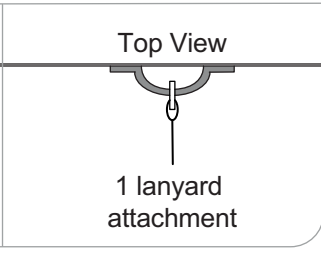
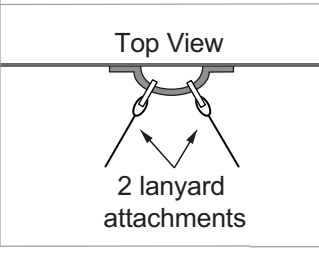
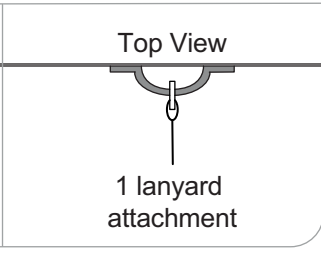
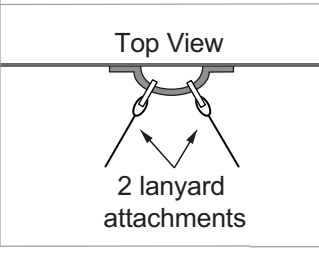
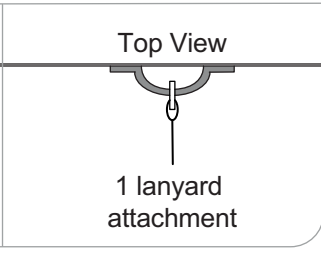
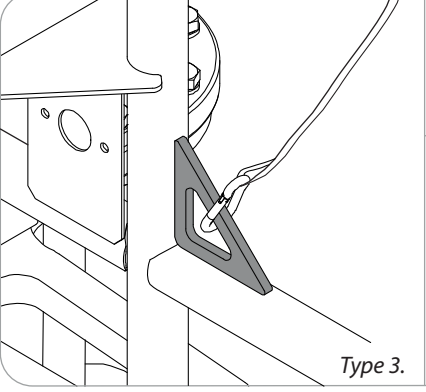
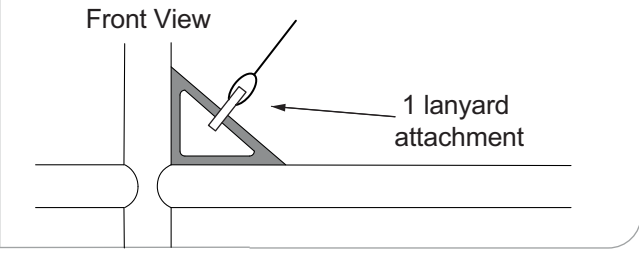
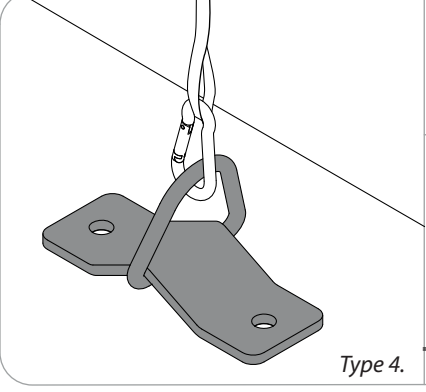
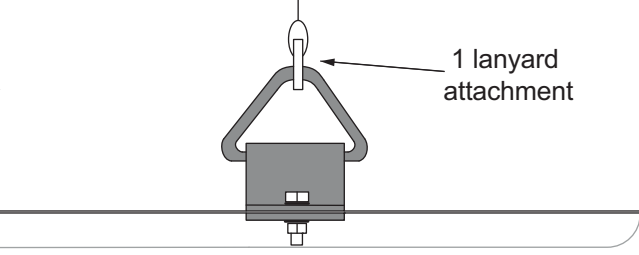
 <p>Type 1.</p>	<p>Harness attachment point Type 1. is rated for one lanyard attachment per loop as shown in the illustrations depending upon platform occupancy rating (see operators manual & decals).</p>		
	<table border="1"><tr><td data-bbox="683 510 1002 763"><p>Top View</p><p>2 lanyard attachments</p></td><td data-bbox="1002 510 1324 763"><p>Top View</p><p>1 lanyard attachment</p></td></tr></table>	<p>Top View</p>  <p>2 lanyard attachments</p>	<p>Top View</p>  <p>1 lanyard attachment</p>
<p>Top View</p>  <p>2 lanyard attachments</p>	<p>Top View</p>  <p>1 lanyard attachment</p>		
 <p>Type 2.</p>	<p>Harness attachment point Type 2. is rated for two lanyard attachments per loop as shown in the illustrations depending upon platform occupancy rating (see operators manual & decals).</p>		
	<table border="1"><tr><td data-bbox="683 916 1002 1169"><p>Top View</p><p>2 lanyard attachments</p></td><td data-bbox="1002 916 1324 1169"><p>Top View</p><p>1 lanyard attachment</p></td></tr></table>	<p>Top View</p>  <p>2 lanyard attachments</p>	<p>Top View</p>  <p>1 lanyard attachment</p>
<p>Top View</p>  <p>2 lanyard attachments</p>	<p>Top View</p>  <p>1 lanyard attachment</p>		
 <p>Type 3.</p>	<p>Harness attachment point Type 3. is rated for one lanyard attachment per loop as shown in the illustrations depending upon platform occupancy rating (see operators manual & decals).</p>		
	<p>Front View</p>  <p>1 lanyard attachment</p>		
 <p>Type 4.</p>	<p>Harness attachment point Type 4. is rated for one lanyard attachment per loop as shown in the illustrations depending upon platform occupancy rating (see operators manual & decals).</p>		
	 <p>1 lanyard attachment</p>		

NOTE: There can be more harness attachment points per machine than the maximum number of occupants allowed in a platform. Refer to the platform decal & specifications table listed in the operators manual for the correct occupancy rating before use.

OPERATORS MANUAL

Safety Rules

All personnel shall carefully read, understand and follow all safety rules and operating instructions before operating or performing maintenance on any SNORKEL aerial work platform

Electrocution Hazard



This Machine is NOT Insulated

Tip Over Hazard



NEVER elevate the platform or drive the machine while elevated unless the machine is on a firm, level surface.

Collision Hazard



NEVER position the platform without first checking for overhead obstructions or other hazards.

Fall Hazard



NEVER climb, stand, or sit on platform guardrails or midrail.

USE OF THE AERIAL WORK PLATFORM: This aerial work platform is intended to lift persons and his tools as well as the material used for the job. It is designed for repair and assembly jobs and assignments at overhead workplaces (ceilings, cranes, roof structures, buildings etc.). All other uses of the aerial work platform are prohibited!

THIS AERIAL WORK PLATFORM IS NOT INSULATED! For this reason it is imperative to keep a safe distance from live parts of electrical equipment!

Exceeding the specified permissible maximum load **is prohibited!** See "Special Limitations" for details.

The use and operation of the aerial work platform as a lifting tool or a crane (lifting of loads from below upwards or from up high on down) **is prohibited!**

NEVER exceed the manual force allowed for this machine. See "Special Limitations" for details.

DISTRIBUTE all platform loads evenly on the platform.

NEVER operate the machine without first surveying the work area for surface hazards such as holes, drop-offs, bumps, curbs, or debris; and avoiding them.

OPERATE machine only on surfaces capable of supporting wheel loads.

NEVER operate the machine when wind speeds exceed this machine's wind rating. See "Beaufort Scale" for details.

IN CASE OF EMERGENCY push EMERGENCY STOP switch to deactivate all powered functions.

IF ALARM SOUNDS while platform is elevated, STOP, carefully lower platform. Move machine to a firm, level surface.

Climbing up the railing of the platform, standing on or stepping from the platform onto buildings, steel or prefab concrete structures, etc., **is prohibited!**

Dismantling the swing gate or other railing components is prohibited! Always make certain that the swing gate is closed and securely locked!

It is prohibited to keep the swing gate in an open position (held open with tie-straps) when the platform is raised!

To extend the height or the range by placing of ladders, scaffolds or similar devices on the platform **is prohibited!**

NEVER perform service on machine while platform is elevated without blocking elevating assembly.

INSPECT the machine thoroughly for cracked welds, loose or missing hardware, hydraulic leaks, loose wire connections, and damaged cables or hoses before using.

VERIFY that all labels are in place and legible before using.

NEVER use a machine that is damaged, not functioning properly, or has damaged or missing labels.

To bypass any safety equipment **is prohibited** and presents a danger for the persons on the aerial work platform and in its working range.

NEVER charge batteries near sparks or open flame. Charging batteries emit explosive hydrogen gas.

Modifications to the aerial work platform **are prohibited** or permissible only at the approval by SNORKEL.

AFTER USE, secure the work platform from unauthorized use by turning both keyswitches off and removing key.

	Page
Introduction	3
Description of Equipment	4
Technical Specification	5
Working Envelope	6
Operator Requirements	7
Warning Notices	8
. Beaufort Scale	9
Towing Instructions	10
Hand Manoeuvring (Friction Drive Option)	12
Pre-Start Checks	13
Power Supply	19
Batteries, & Power Pack	15
Setting Up	16
Extending Structure	18
. Basket Controls	18
. Ground Controls	20
Safety Harness	21
Emergency Controls	
. Emergency Stops	21
. Emergency Lower (Electronically)	22
. Emergency Lower (Manually)	23
. Emergency Raise Outriggers	24
. Emergency Cage Overload	24
. Emergency Battery Isolation	25
Stowing the Machine	26
Maintenance	
. Daily Checks	27
. Weekly and Monthly Checks	28
. Slew Drive and Limit Switches	29
. Trailer Lighting Diagram	30
Appendices	
<i>Petrol/Bi-fuel Option.</i>	31
<i>Generator Option.</i>	32
<i>Mains connection.</i>	33

The **SNORKEL TL49J** is a class leader, offering several features as standard that other manufacturers only provide as optional extras.

These include powered basket rotation and fully proportional hydraulic controls, at both basket and ground level.

The third flick boom, with 130 DEGREES working arc, guarantees access to the most hard to reach places, while the 90 DEGREES basket rotation provides the precision positioning that is vital for working in tight spaces.

SNORKEL Powered Access has a global reputation for innovation and a proud heritage in the design and manufacture of high quality powered access equipment.

The company was founded in the US more than 65 years ago, on the principle of constantly improving service excellence for end users.

Every model in our growing range of versatile, trailer mounted units is a class leader and together they have set new industry benchmarks.

Our commitment to research and design, plus 250,000sq ft of same site fabrication, build and support capacity, mean SNORKEL can offer complete solutions to meet even the most demanding access applications.

SNORKEL has third party accreditation to quality standard ISO 9001 and the full range carries the CE mark, complying with or exceeding all relevant standards and EC directives.

SNORKEL Powered Access is a member of the International Powered Access Federation (IPAF).

To ensure you are fully aware of safety and operational information, the following symbols are used throughout this manual;



This type of box contains, Points of operation to NOTE.



The information contained in this type of box contains, WARNING text. It gives Warnings about the risk of Damage to equipment, and possibly personnel.



The information contained in this type of box contains, DANGER text. It gives Warnings about the risk of PERSONAL INJURY to the operator and or others.

DESCRIPTION OF EQUIPMENT

The SNORKEL TL49J is of the parallel linkage vertical boom design, mounted on a road towable trailer. The unique, yet very simple boom configuration gives the maximum safety and control ability combined with a robust construction to withstand a heavy working environment

The TL49J machine is designed for two man capacity (200 kg S.W.L.).

The machine incorporates a bottom boom with tie-rod, a short vertical boom and a top boom with a telescope section. The TL49J also has an independent hydraulically operated flick-out boom and rotating cage for extra manoeuvrability.

The hydraulic system is of a failsafe design throughout, with built in hydraulic lock valves on all of the rams as a precaution against hose failure. The machine is controlled by means of proportional manual controls of the 'direct hand' lever operating type. These valves are located at both the base and in the cage, as standard.

Electrically operated emergency lowering valves are fitted as standard to allow the machine to be lowered from the base and basket.

The hydraulically operated outriggers are fitted with load sensing interlocks, to prevent the booms from being raised without the outriggers being extended and under load. An interlock prevents the hydraulic outriggers being accidentally retracted while the booms are raised. A simple system of warning lights show the power supply is on and each of the outriggers is under load.

Performance.

Maximum Working Height	17.00 m
Maximum Working Outreach:	9.10 m
Capacity (2 man working):	200 kg
Slewing Arc:	680°
Airborne Noise Emissions (Battery):	70 dB(A)

Construction Standards.

The machine complies fully with the requirements of the following EEC Directives:
Directive 98/37/EC – the 'Machinery Directive'.
Directive 89/336/EEC – the 'Electromagnetic Compatibility Directive'.
Directive 73/23/EEC – the 'Low Voltage Directive'.

EN 6020-1/1993 'Safety of Machinery.'

The machine is designed and tested in accordance with all relevant B.S.I and European Standards including EN280.

Cage Dimensions

Length	1.20m
Width	0.80m
Guard-rail Height	1.10m
Toe-board Height	0.15m

Operating Dimensions

Maximum Working Height	17.00m
Maximum Cage Height	15.00m
Maximum Outreach (From centre of rotation)	9.10m

Travel Dimensions

Towing Length	7.10m
Closed Width	1.75m
Closed Height	2.10m
Weight	(Battery Model) 2250 kg (un-laden)
	(Battery Model + Friction Drive) 2395 kg (un-laden)
	(Bi-fuel Model) 2300 kg (un-laden)

Operating Parameters

Safe Working Load	200 kg
Maximum Horizontal Pull	400N
Maximum Wind Speed	12.5 ms ⁻¹
Rotation	680°
Cage Slew	90°

Equipment

Bottom Ram	Double acting: Bore Ø 80.0 mm Rod Ø 50.0 mm
Top Ram	Double acting: Bore Ø 80.0 mm Rod Ø 50.0 mm
Tele' Ram	Double acting: Bore Ø 65.0 mm Rod Ø 45.0 mm
Flick Ram	Double acting: Bore Ø 60.0 mm Rod Ø 40.0 mm
Stabiliser Ram	Double acting: Bore Ø 70.0 mm Rod Ø 40.0 mm
Bottom & Top Ram Lock Valves	Pilot operated over centre valves
Control Valve (Cage)	Monoblock unit consisting of seven double acting spools
Control Valve (Ground)	Monoblock unit consisting of five double acting spools
Control Valve (Stabiliser)	Monoblock unit consisting of four double acting spools
Bushes	Acetol resin polymer with sintered bronze base (DX)
Pivot Pins	Stainless Steel Bright Bar To Grade BS970 303 S31 CW, & MecaVal 147m, Tuftride TFI-AB1 coated.

OPERATING ENVELOPE

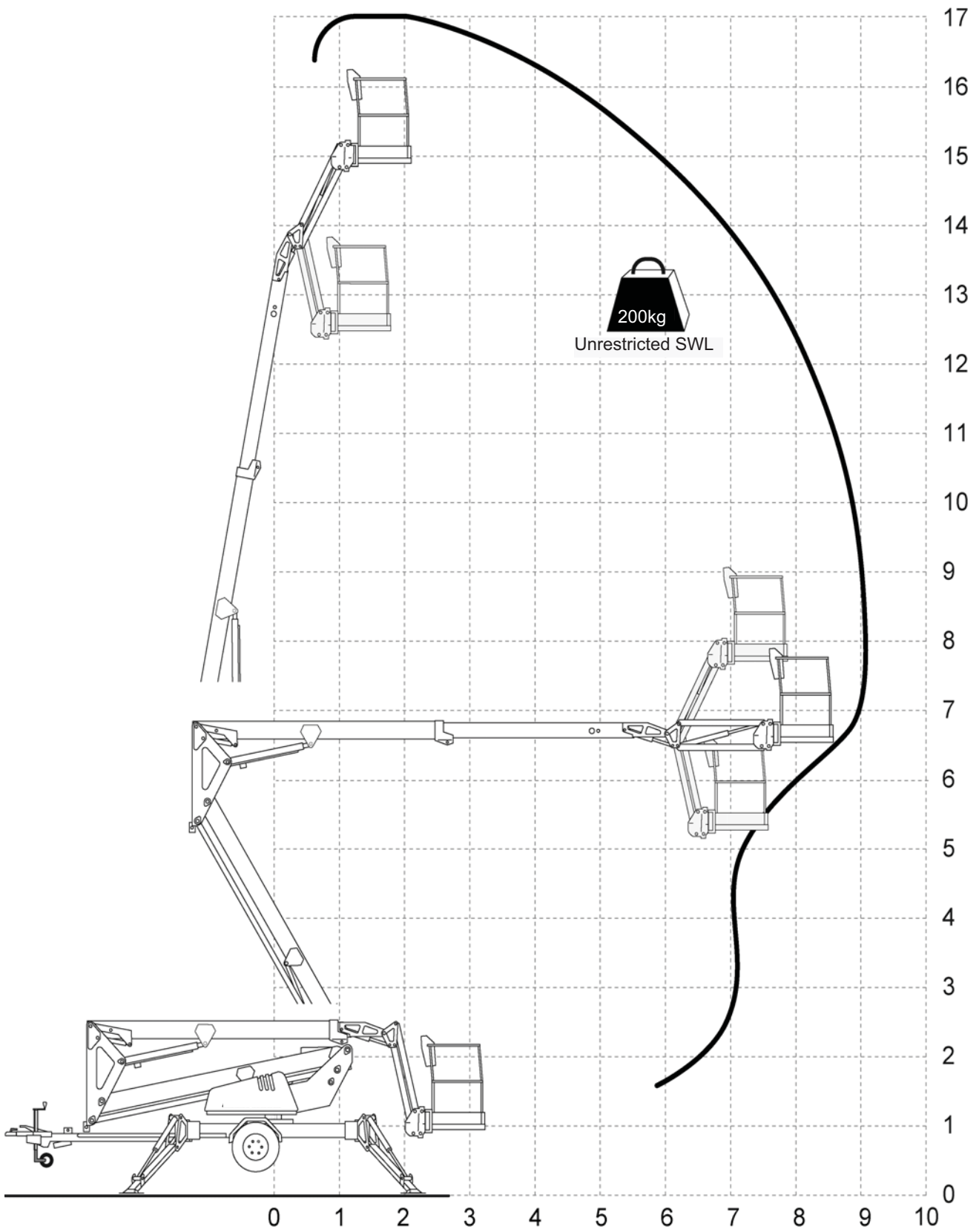

Height and Distance in Metres.

Please read this carefully, and ensure you have received the correct training prior to operating this machine.

1. To operate the machine you must be medically fit and have no problems with eyesight or hearing.
2. You must have a good head for heights.
3. Your primary concern must be the safe operation of the work platform, the safety of the people working with you, and the safety of other persons in your working area.
4. You must be familiar with the contents of this manual, and at no time attempt to operate the machine beyond the recommended limits.
5. The proper care of the work platform is a major factor in ensuring the safety of those who work with it.
6. You must not misuse the machine or ignore or interfere with the devices that have been provided to maintain safety.
7. Operation of the machine should be restricted to personnel who have been authorised to operate the equipment and have received proper training.

WARNING NOTICES

1. **DO NOT** operate this machine unless you have been fully trained in its safe use.
2. **DO NOT** operate the machine on soft, slippery or sloping ground unless adequate precautions have been taken.

The stabilisers are designed to operate on firm level ground with a minimum bearing strength of 50N/cm².

The maximum load imposed by an outrigger is 12.5kN.

Advice should be obtained from SNORKEL as to the type of supports and precautions required before attempting to operate the machine outside these parameters.

3. **DO NOT** use any equipment in the basket to increase the reach or working height of the machine, e.g. ladders.
4. **DO NOT** fit any additional equipment to the machine that would increase the wind loading, e.g. notice boards.
5. **DO NOT** use the machine for any application that may produce special loads or forces: the manufacturer, SNORKEL Powered Access, must be consulted for approval of special applications prior to use.
6. **DO NOT** use the machine close to live electrical conductors. The minimum safe working distance for a machine working near overhead power cables is the maximum extended length of the booms plus 15 metres, measured with the booms pointing towards the lines, i.e. safe working distance for the TL49J is 24 metres. It is the operator's responsibility to ensure that, when working in the vicinity of live overhead high-voltage lines, the minimum safe working distance is maintained. Erect a simple barrier tape at the safe distance.

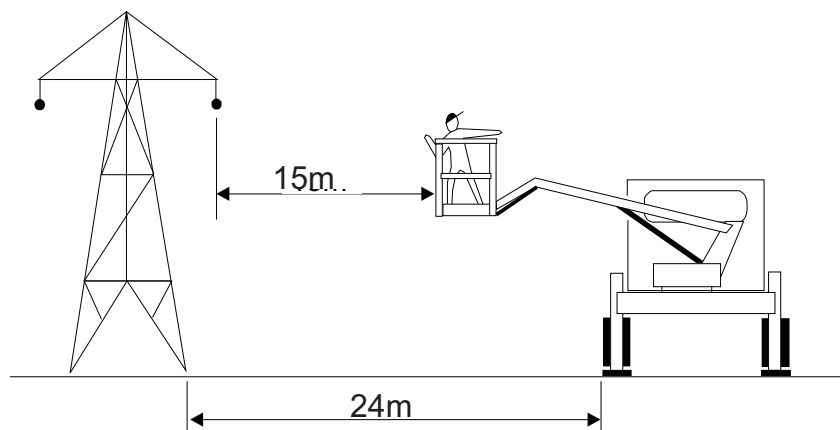

7. **WORKING CLOSE TO POWER CABLES** – if work has to be carried out at less than the safe working distance, the operator must **ensure that the electricity supply has been switched off**. Before commencing work, a written permit to work must be obtained from the owners of the power cables or the responsible authority.

8. **DO NOT** operate the machine unless all four outriggers are down and in full contact with the ground. The machine must be level and the **wheels lifted visibly clear of the surface** before the booms are raised.

9. **DO NOT** move the machine with the basket raised and never allow cage or booms to slew into the path of oncoming vehicles.

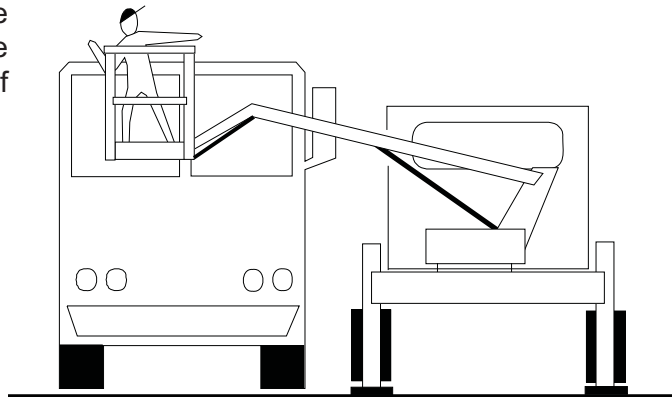

10. **DO NOT** operate the machine if the wind speed exceeds 12.5 m/s. Be aware that, when working near high buildings or structures, shielding and funnelling effects may cause high wind forces on days when the nominal wind speed in the open is low. Wind speed can either be measured from the work platform with a hand held anemometer or estimated using the Beaufort Scale.

BEAUFORT WIND SPEED SCALE

The Beaufort Scale of wind force is accepted internationally and is used in communicating weather conditions. It consists of numbers 0 - 12, each representing a certain strength of velocity of wind at 10m (33ft.) above ground in the open.

Approximate corrections for wind speeds at other heights are:

- 2m subtract 30%;
- 3m subtract 20%;
- 6m subtract 10%
- 15m add 10%;
- 30m add 25%

Beaufort Scale	M/Sec	Ground Conditions
3	3.5-5	Leaves and small twigs in constant motion; wind extends light flag.
4	6-8	Raises dust and loose paper; small branches are moved
5	9-10	Small trees in leaf begin to sway; crested wavelets on inland waterways.
6	11-13	Large branches in motion; umbrellas used with difficulty.
7	14-17	Whole trees in motion; inconvenience felt when walking against wind.
8	18-21	Breaks twigs off trees; generally impedes progress.
9	22-24	Slight structural damage occurs (chimney pots and slates removed)

TOWING INSTRUCTIONS

Trailer mounted machines are fitted with suspension units that may be safely towed behind a car or van at speeds of up to 50mph (80km/h) where permitted.



1. Before towing, check the capacity of the vehicle being used. (Machine weight will increase if optional extras are fitted)
2. Ensure that the road tyres and brakes are in good, serviceable condition.
3. Ensure that all booms are fully lowered and both the transit pins are fitted through the loops and secured with the "R" clip on the end of the chain.



4. Ensure that all outriggers are fully raised.



5. Use the Jockey Wheel to raise or lower the tow bar coupling to position the machine above the 50mm ball hitch on the towing vehicle.

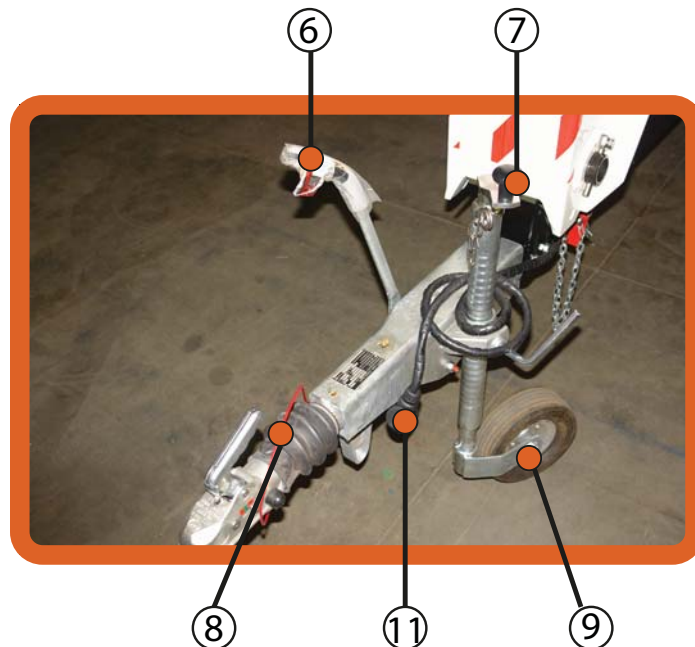

6. Apply the handbrake.
7. Lower the tow bar coupling down onto the ball hitch using the Jockey Wheel
8. Secure the breakaway cable, (Ensure correct engagement of 50mm ball).
9. Fully raise the Jockey Wheel and lock in position.
10. Release the Handbrake.
11. Plug in the trailer lights (7 pin plug) and check that both vehicle and trailer lights operate correctly.

HAND MANOEUVERING (Optional)

1. Ensure that the booms are fully lowered, all outriggers are fully raised and the machine is in a manoeuvrable condition.
2. Engage the the friction drive cylinders against the trailer tyres by pulling actuating levers forward and down until they lock overcentre.



3. Ensure the power selector switch is set to Base.
4. Disengage the handbrake, and ensure that the Jockey wheel directional locking pin is removed



5. Traction is controlled via the 2 hydraulic levers on the R/H side of the chassis.

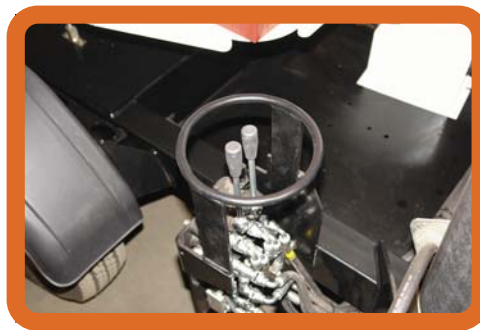

6. The left lever controls the left motor and the right lever the right.

Operating only the left lever forward will turn the machine right and the right lever will turn the machine left, operate both levers together for parallel drive.

7. When the machine is in position replace handbrake.



Ensure friction drive cylinders are disengaged prior to platform operation or towing.

The following Pre-Start Checks should be carried out before taking the machine to the place of work.



1. **Damaged or Loose Fittings.**
Visually Inspect the machine for signs of wear and tear, damage, loose or missing parts.
2. **Wheels. (For towing only)**
Check tyres are at the correct pressure, TL49J = 76psi (5.25 bar).
3. **Hydraulic fluid.**
The hydraulic oil tank is located underneath the slew cover on the right hand side of the machine (looking from the cage end), Ref, Fig.2, section J With the booms and outriggers in the transport position, the hydraulic oil level should be visible between the upper and lower marks of the Sight Glass.

Top up with ISO Grade 22 hydraulic oil if necessary.

Do Not Overfill the Tank



Serious injury or even death may result by not carrying out the following checks of the interlock system before the platform is used!



4. **Safety Switches.**
Visually check the cage overload switch is free from damage.

Check all limit switch arms are free from damage and move easily (outrigger switches shown in Fig.6).

With outriggers in transport position, it must not be possible to operate the extending structure. With outriggers deployed, under load and top or bottom boom raised approximately 50mm, it must not be possible to operate the outrigger controls.

The flick boom is not interlocked with the outriggers.



PRE-START CHECKS

5. **Emergency Stop Switches.**

Emergency stop switches must operate correctly. Check that each stops the machine's controls and that restarting is prevented until all stop switches are unlatched.

6. **Emergency Lower/Slew.**

With the top and bottom booms raised approximately 500mm each and the unit switched off, check:

The emergency lower switch located in the basket and ground control stations, lowers the booms when operated.

The emergency slew, telescopic boom retraction can be operated by using the hand pump and control lever at the ground control station.

To Reset the hydraulic system after checks;

- Fully slew the Basket to the right, so that the ram is fully extended.*
- Fully extend the Outriggers while still maintaining Level. (check the bubble)*
- Using the ground controls, fully extend Top, Bottom and Telescopic Booms.*
- Fully extend the Flick Out Boom.*

All rams must be fully extended at the same time before returning them to their transit position.



*If the Emergency Lower is used during normal operation, **DO NOT** use the machine, **Contact your local SNORKEL representative.***

7. **Emergency Hand Pump.**

With the unit set up for working (i.e. outriggers down, under load and the machine level with wheels clear of ground) it is possible to lower the cage using the emergency hand pump.

8. **Battery Power (Where applicable)**

Check batteries are fully charged and topped up with distilled water (these are fitted under the slew cover on both sides of the platform).

Hydrometer reading should be 1280-1320sg.

With machine level, the distilled water should cover the plates by approximately 6mm.

9. **Mains Power (Where applicable)**

Check that the voltage and frequency of the power input matches that of the motor. All extensions must be a minimum of 2.5mm², and no longer than 10m due to possible voltage drop.

10. **Petrol/diesel Power (Where applicable)**

Check that there is sufficient oil and fuel to complete a full working shift.

Battery Power, 24V DC.

Ensure batteries have been fully charged before use and that the Battery Isolating Plug is securely connected.

Mains Power, (OPTIONAL)

Connect the mains supply, either 110V or 220/240V A.C., depending upon the motor specification. Check the motor is running when the key is turned to the **ON** position.

All extensions must be a minimum of 2.5mm², and no longer than 10m, due to possible voltage drop, which will damage the motor.



Petrol/diesel Power, (OPTIONAL)

Check the fuel and oil levels of the engine. Switch on the ignition using the key switch on the slew mounted legend panel. Check the engine runs using the start and stop buttons in the basket.



fig 1.

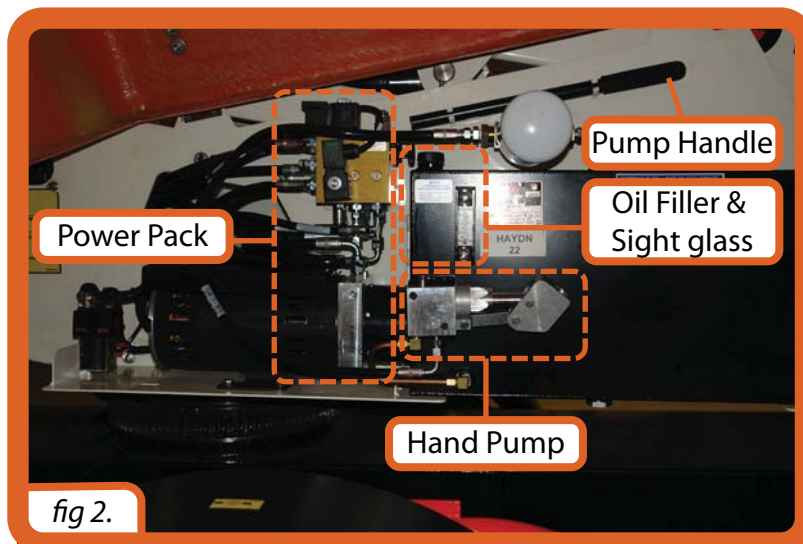

fig 2.

SETTING UP

1. Park the unit in an appropriate location at the workplace.

Do not attempt to set up the machine on steep slopes, ramps or soft ground.



2. Apply the handbrake on the trailer and remove from the towing vehicle.

3. With platform key switch set to 'Ground' (**Fig 3**)

lower the outriggers by keeping the '**Outrigger Motor Run**' button (**Fig 4**) pushed in, operate the appropriate '**Outrigger control lever**' (**Fig 5**), until all four are **25mm to 50mm** from the ground.

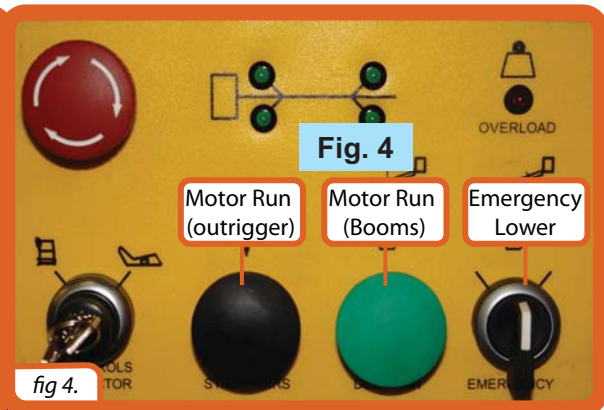
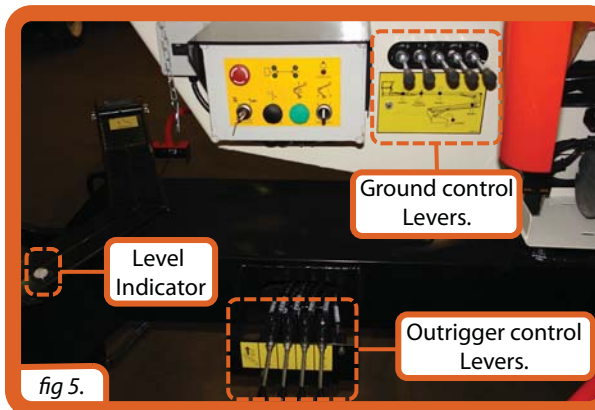

4. Lower the Outriggers two at a time starting at the tow bar end (No's 3&4) until the jockey wheel just clears the ground.
5. Lower Outriggers 1&2 until the green LED display indicates that they are under load. (As shown below)

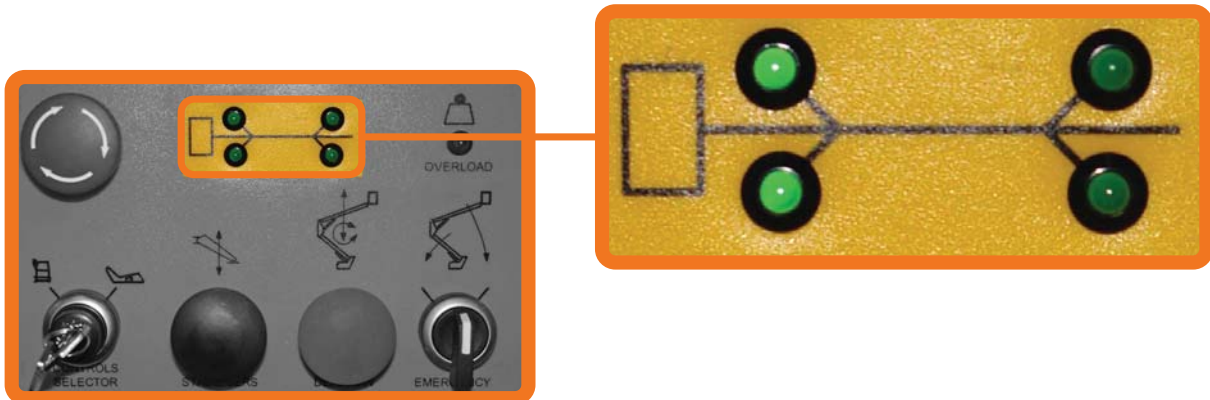

Take EXTREME care NOT to ground either the Basket, or the Jockey Wheel during the next step.

6. Repeat this sequence for Outriggers 3&4.
7. By alternating from 1&2 to 3&4, carefully inch down each pair of Outriggers until all four Outriggers are fully deployed, and the wheels are well clear of the ground.
8. Now, by using the Level indicator (Fig.5), raise opposite Outriggers until the bubble and indicator ring are concentric (i.e., the bubble rests in the centre).
9. Check that each LED on the Ground Control panel is still illuminated. This indicates that each foot is in firm contact with the supporting surface.



The unit is designed to operate on a supporting surface of minimum bearing strength of 50N/cm².



The maximum outrigger load is 12.5kN.

EXTENDING STRUCTURE

1. Remove and correctly stow the Transit Pins, from both the Upper and Lower Booms.

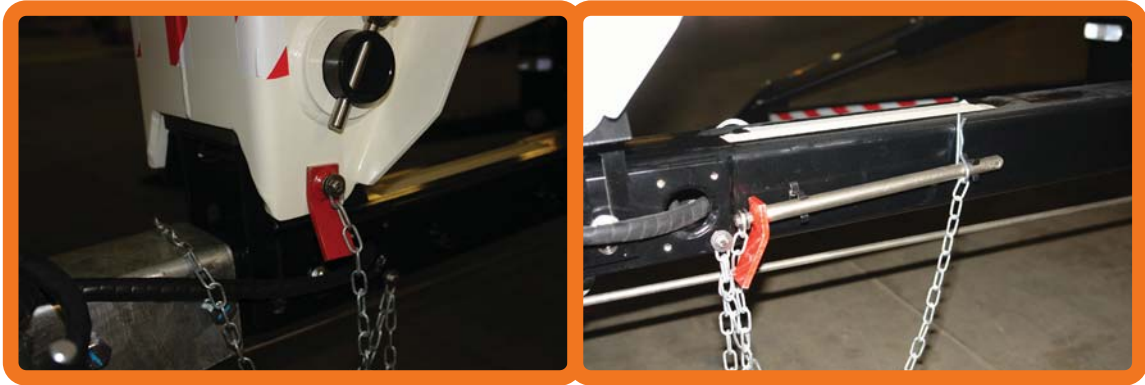

2. At the Ground Control Station, turn the key to 'Basket'. (See Fig. 3)
3. Climb into the basket. Check that all Emergency Stop Switches are released (twist release). The platform may now be raised, lowered or slewed in any direction by operating the control levers at the basket, whilst depressing the motor run button (DEADMAN).

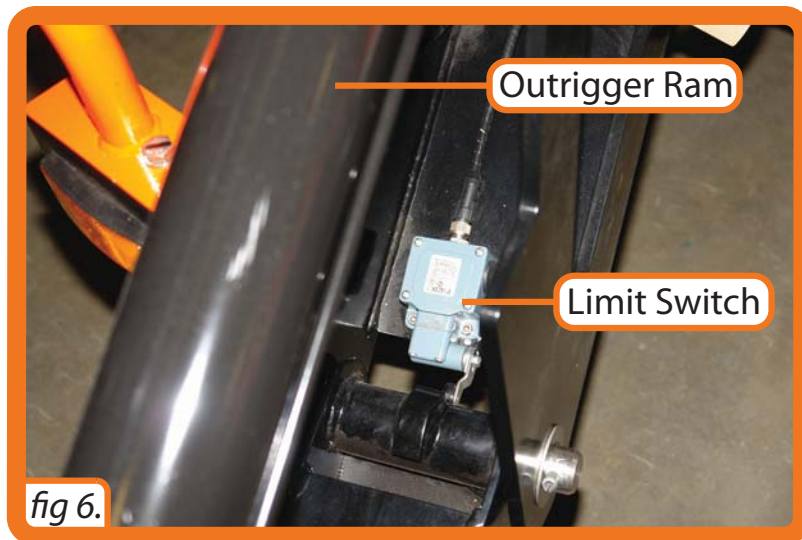

Before raising, ensure there are no overhead obstructions or power cables and the outriggers are properly extended and secure.



Take EXTREME care when slewing both basket and turret, at low levels.

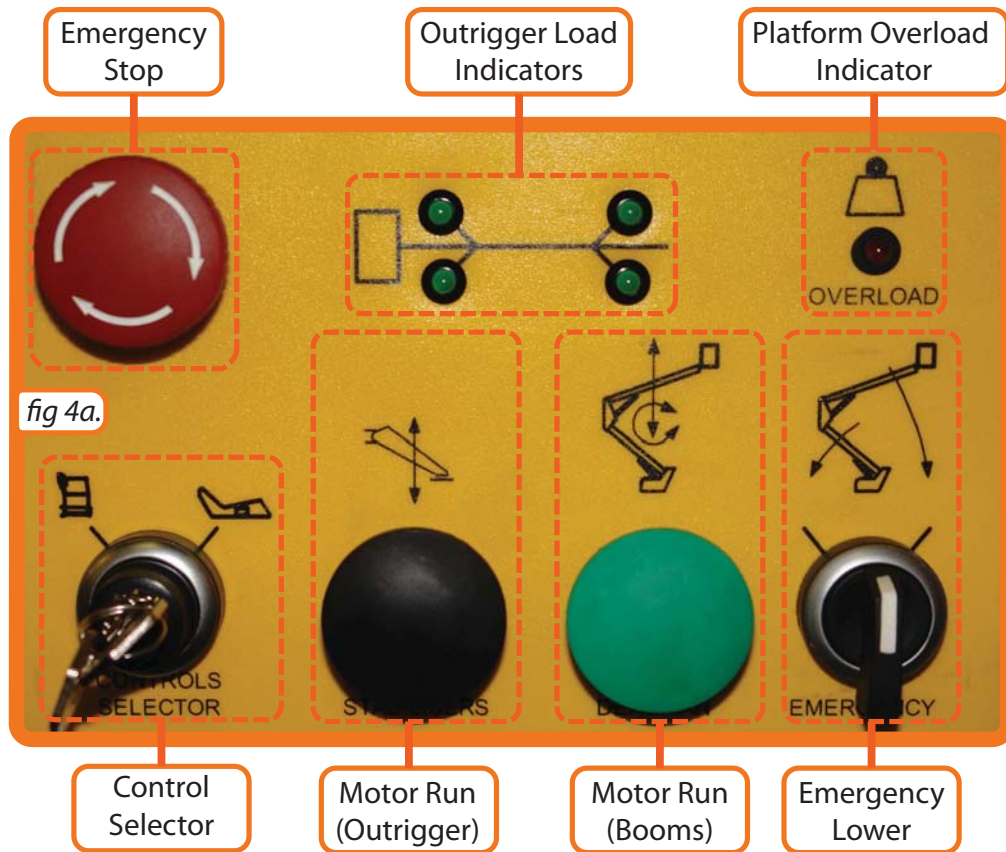
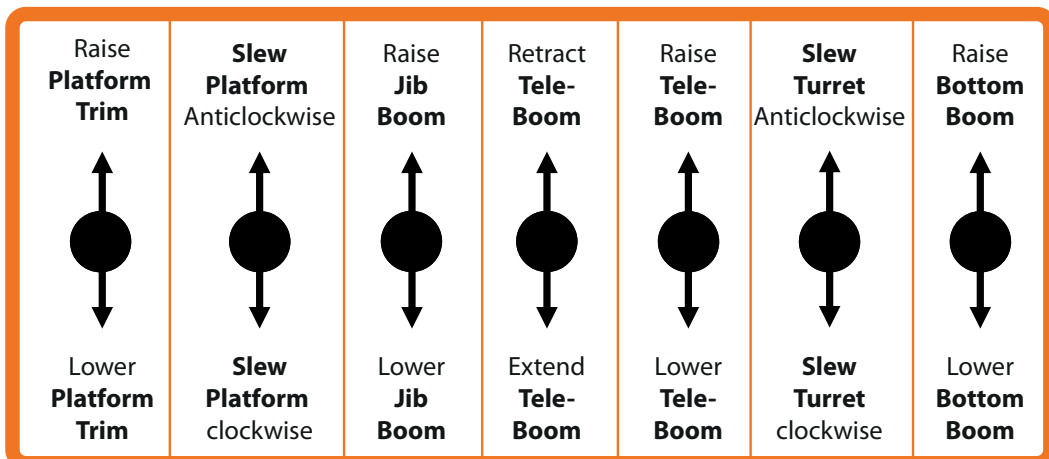
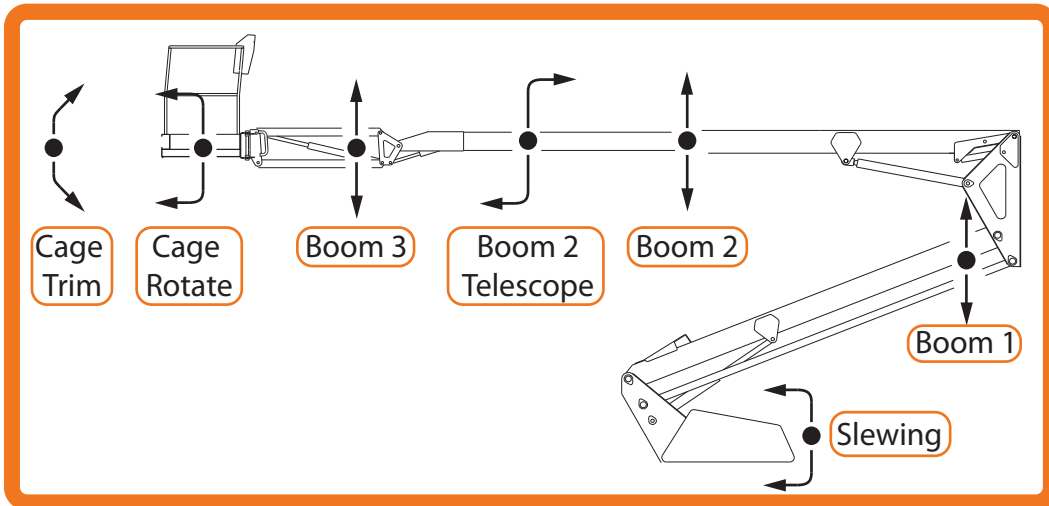

fig 4a.

4. Explanation of the Basket Control Station, Directional Control Levers.



EXTENDING STRUCTURE

5. A duplicate set of controls (excluding Slew Basket) is mounted on the Slew Turret under the right hand side cover, which allows the platform to be operated from the Ground.
6. At the Ground Control Station, turn the key to 'Ground'. (See Fig.3)
7. Explanation of the Ground Control Station, Directional Control Levers

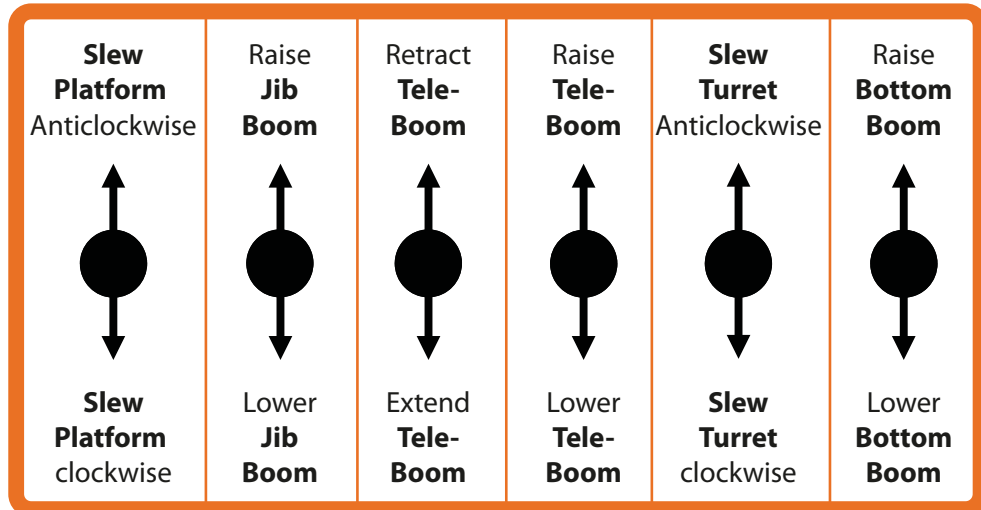
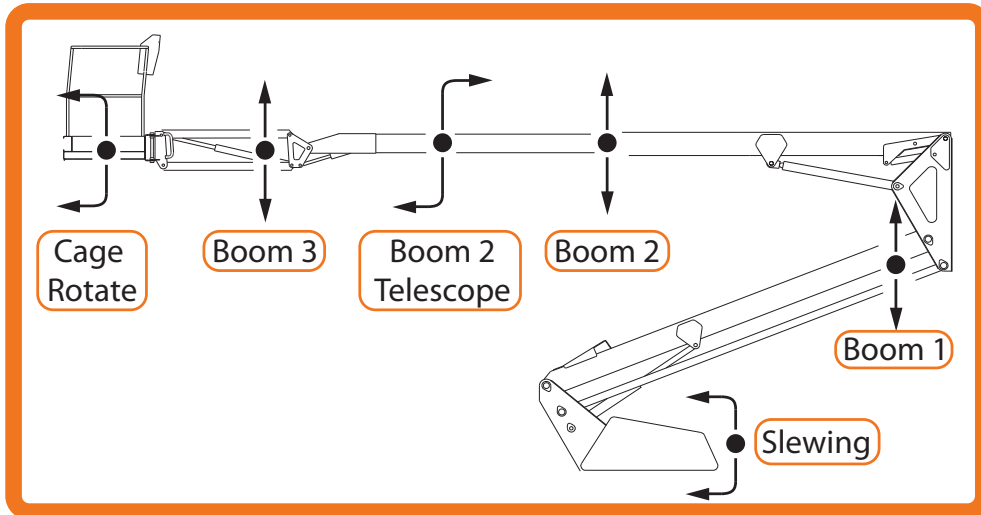

EMERGENCY CONTROLS

1. Emergency Stop

Emergency Stop buttons are fitted on the machine to stop the motor in an emergency.

There are 2 Emergency Stop Buttons, one in the basket, and one on the ground control panel.

The emergency stops are 'Reset' by twisting.



EMERGENCY CONTROLS

Emergency Lower.

In the event of a power failure, There are two ways of Safely lowering the basket.

2. Emergency Lowering, *method one*

The operator or someone on the ground, can lower the booms to a safe position by activating the Emergency lowering selector switch both ways, on the Basket Control Panel and the Ground Control Panel.

The Flick Boom cannot be lowered by activating the Emergency Lowering Switch.



The Emergency lowering valve will automatically close when the switch is released.



If the Emergency Lower is used due to a machine defect, ***DO NOT*** use the machine, ***Contact your local SNORKEL representative.***



If the Emergency Lower is used, The TOP and BOTTOM BOOMS must be fully extended then fully lowered before work can continue.

After Emergency lowering, any further POWERED lowering could cause an AIRLOCK in the hydraulic system.

This could cause the Hydraulic operations to Fail.

ALL BOOMS MUST BE FULLY EXTENDED/RAISED, THEN LOWERED BEFORE WORK CAN RECOMMENCE.



3. Emergency Lowering a, method two.

You can operate the hand pump from the ground control station cage and operate the boom controls and slewing functions.

To operate the hand pump, insert the lever over the pump shaft, then lower the lever to a convenient position to start pumping.

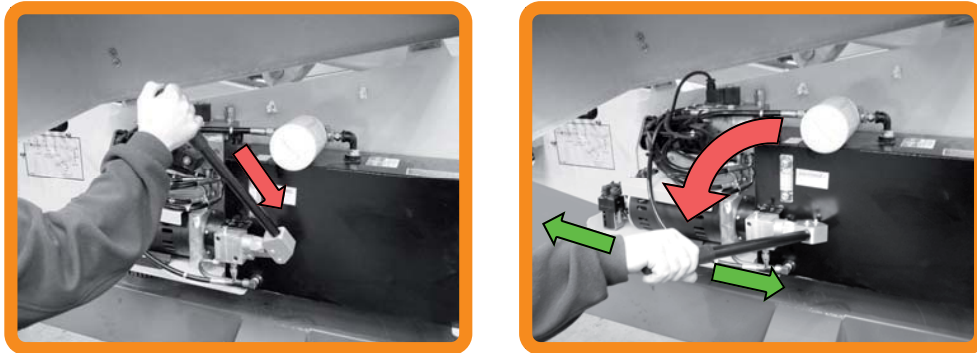

Move a control lever to the required direction of movement, and operate the hand pump. When the machine starts to lower, continue depressing the control lever.



Vigorous pumping is required to lower and slew the machine.

EMERGENCY CONTROLS

4. Emergency Procedure, Manual Raising of Outriggers.

In the event of power failure, the outriggers can be raised to their transport position.

First the hand pump hose fitted to port **HP1**, must be **redirected** from **HP1**, to **port HP2**,

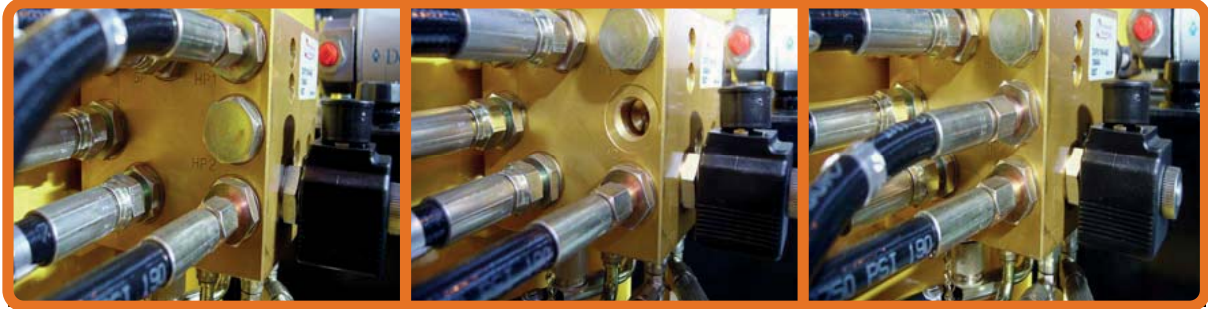

and the **blanking plug** from HP2 must be replaced into **HP1**, using a **22mm spanner**.

Once connected, **move an Outrigger Control Lever in the required direction of movement**, and operate the hand pump. When the Outrigger starts to raise, continue depressing the control lever.

Some hydraulic oil will be lost during this procedure. This will still allow Emergency operations, but will need to be replaced before full normal use can resumed.



5. Cage Overload

In the event of the cage being overloaded, an audible alarm will sound and the cage controls will cut out.

To **re-start**, enough load must be removed from the cage so that the alarm stops sounding.

In cases where the overload can not be immediately removed or the cage has fouled, then the overload override selector switch can be used to move the platform to a safe position so that the overload can safely removed.



The Key, Motor Run/Deadman and a Control Lever must be operated at the same time to effect this action



6. Emergency Battery Isolating Plug.

Disconnecting this plug will isolate the batteries from the powerpack and operating circuits.



Before operating this machine, it is important that both the Operator and another responsible person on site, is aware of the position and function of the following:

- A) Emergency Stop Buttons.**
- B) Emergency Lowering Buttons.**
- C) Emergency Slew Drive Shaft.**
- D) Battery Isolating Plug.**



STOWING THE MACHINE

1. Fully lower all the booms.
2. Engage the Transit Pins, and lock in place using 'R' clip.
3. With platform keyswitch set to '**Ground**':

Raise the outriggers by simultaneously depressing the '**MOTOR RUN Outrigger**' button and using the appropriate control levers, two at a time, alternating between the cage and tow bar end until the road wheels are in contact with the ground.

Only when the road wheels are in contact with the ground should the unit be lowered further until the jockey wheel makes contact with the supporting surface.

Now fully raise the outriggers until they are in the stowed position.

Switch off the platform and ensure all loose items/covers are secure before towing the unit.

The machine is now ready for transportation.

TRANSPORT PIN LOCATIONS – SHOWN READY FOR TRANSPORT

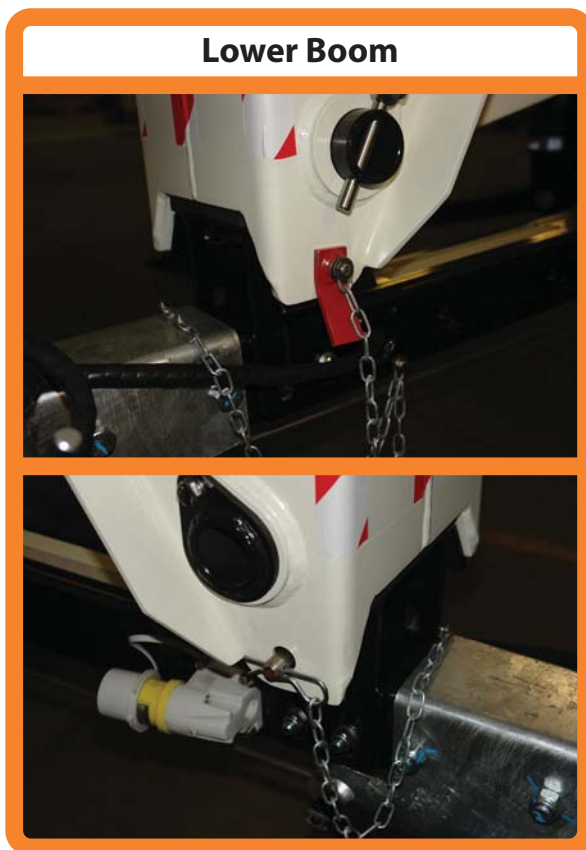

The unit must have a thorough inspection carried out every 6 months in accordance with LOLER Regulations 1998 and a Certificate of Thorough Inspection produced by a competent person.



Always ensure the machine structure is in good, sound, undamaged condition. Any inspection procedure is always aided by keeping the machine clean. NB. Do not steam clean the battery charger or electrical components.



Daily Checks.

1. **Damaged or Loose Fittings.**
Visually Inspect the machine for signs of wear and tear, damage, loose or missing parts.
2. **Wheels.**
Check tyres are at the correct pressure, TL49J = 76psi (5.25 bar).
3. **Hydraulic fluid.**
The hydraulic oil tank is located underneath the slew cover on the left hand side of the machine (looking from the cage end), Ref, Fig.2, section J. With the booms and outriggers in the transport position, the hydraulic oil level should be visible between the upper and lower marks of the dipstick.

Do Not Overfill the Tank

Top up with ISO Grade 22 hydraulic oil if necessary.



4. **Safety Switches.**
Check all limit switch arms are free from damage and move easily outrigger switches.

With outriggers in transport position, it must not be possible to operate the extending structure.

With outriggers deployed, under load and top or bottom boom raised approximately 50mm, it must **NOT** be possible to operate the outrigger controls.

The flick boom is not interlocked with the outriggers.



5. **Emergency Stop Switches.**
Emergency stop switches must operate correctly. Check that each stops the machine's controls and that restarting is prevented until all stop switches are unlatched.



The unit must have a thorough inspection carried out every 6 months in accordance with LOLER Regulations 1998 and a Certificate of Thorough Inspection produced by a competent person.



Always ensure the machine structure is in good, sound, undamaged condition. Any inspection procedure is always aided by keeping the machine clean. NB. Do not steam clean the battery charger or electrical components.

Weekly Checks.

1. Apply grease to the slew gear wheel and all grease nipples.
2. From the Ground controls, Fully extend the Telescopic Boom and visually inspect along its entire length for signs of wear and tear damage or deformation.
3. Check battery acid level, top up with distilled water if required (maximum 6mm over plates when battery is standing level), and check mains cable wiring.

Monthly Checks.

1. Thorough inspection to be carried out by a competent person.(LOLER)

FOR ENGINE MAINTENANCE REFER TO MANUFACTURES GUIDELINES

Slew Drive Gears.

The slew drive gear is designed to be largely maintenance free. However, we recommend the gear teeth be greased on a monthly basis with a high pressure grease. Additionally, the ring gear and gear box should be greased on a six monthly basis. The grease nipple for the ring gear is on the top face of the slew gear, set between the fixing bolts. It can be accessed by lifting one of the side covers, and slewing the structure appropriately.

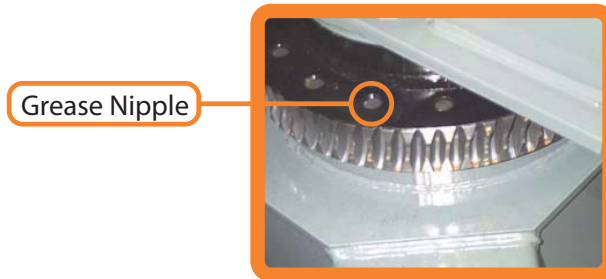

The ring gear should be inspected on a six monthly basis for excessive play. It is unlikely there will be any wear if the machine is maintained correctly.



To check the gear, place a payload of approximately 80Kg in the platform. Elevate the lower boom to approximately half way. Then gently elevate the top boom, whilst observing the ring gear. Excessive wear will be observed by noticing more than 0.5mm movement between the inner and outer bearing rings.

Checking Limit Switch Operation.

The limit switches require no maintenance, other than a visual inspection, on a pre operation basis. This is an important check, to ensure the switch is not mechanically damaged, and the roller is always in contact with the cam, when not under load.

The switch operation can be simply checked, by observing the LED display when deploying the stabilizers. As an outrigger foot touches the ground and becomes loaded, the appropriate light will change to green. This indicates that the switch contact has operated correctly.

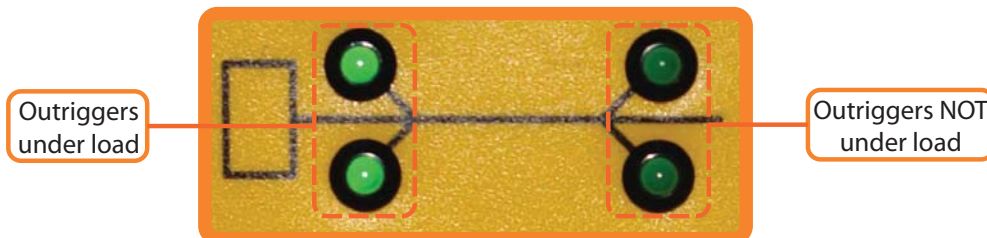

If the LED displays green at any other time then the machine must not be operated, until the fault is rectified.

13 PIN CONNECTOR

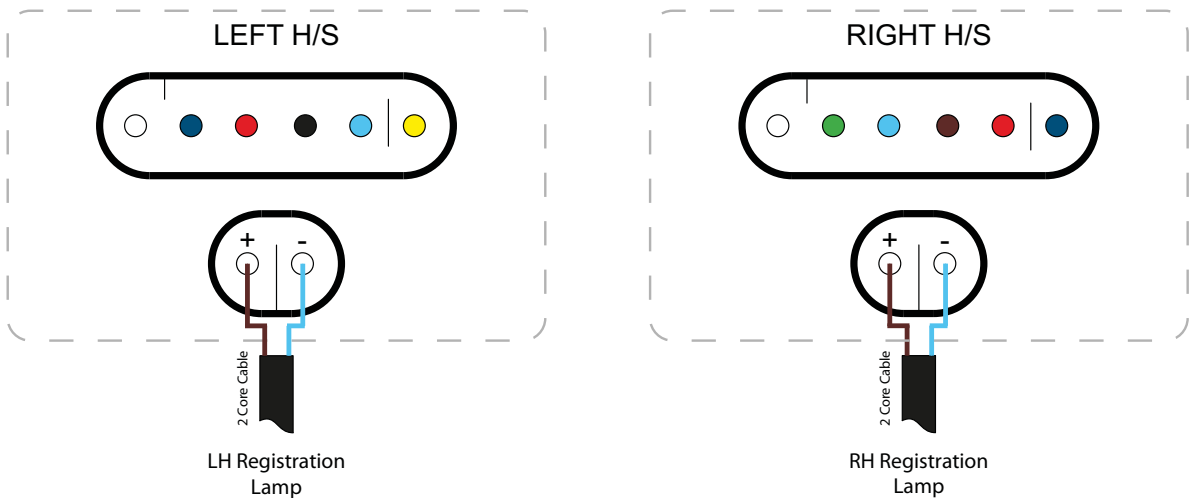
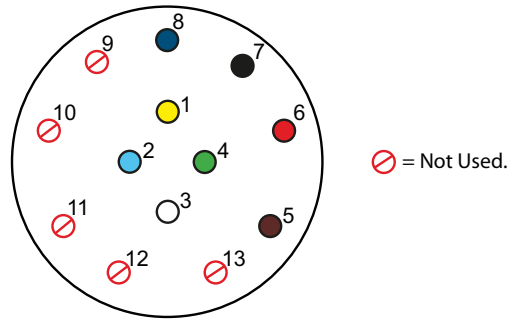

13 PIN CONNECTOR

PIN	FUNCTION	COLOUR
1	LH INDICATOR	YELLOW
2	FOG LAMP	BLUE
3	NEGITIVE	WHITE
4	RH INDICATOR	GREEN
5	RH TAIL LAMP	BROWN
6	BRAKE LAMP	RED
7	LH TAIL LAMP	BLACK
8	REVERSING LAMP	DARK BLUE
9	NOT USED	N/A
10	NOT USED	N/A
11	NOT USED	N/A
12	NOT USED	N/A
13	NOT USED	N/A

This machine variant is fitted with a petrol/diesel engine, with remote start and stop

Diesel Engine



Petrol Engine



This manual does not cover the maintenance of the engine.

For engine maintenance details refer to the manufacturers handbook.

Prior to operating the engine, follow these simple guidelines;

- a) ensure there is adequate fuel for the task in hand
 - b) check the oil level prior to starting the generator
 - c) Check battery electrolyte level. (Where applicable, Lead Acid batteries Only)
1. To use the engine, simply switch the fuel on, with the lever.



2. With the key, turn the ignition to start, motor on, releasing the starter when the engine fires.



3. Or, if using the basket controls turn the key to engine and push the start button.



4. With the engine running, It will now be possible to operate the machine Hydraulic controls as long as there is power in the main batteries.

This machine variant is fitted with a 2.2 kva generator, with remote start and stop.

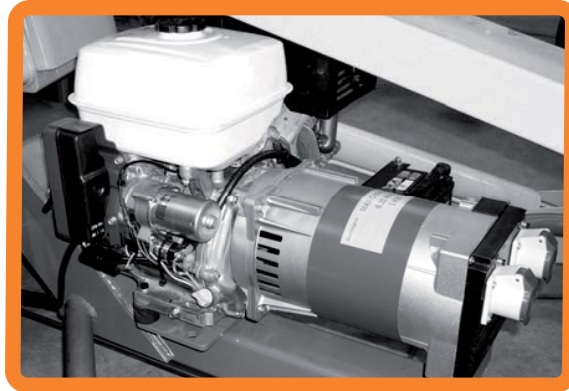

This manual does not cover the maintenance of the generator.

For maintenance details refer to the manufacturers handbook.

Prior to operating the generator, follow these simple guidelines;

- a) ensure there is adequate fuel for the task in hand
 - b) warm the engine prior to switching off at the platform.
 - c) check the oil level prior to starting the generator
-
1. To use the generator, simply switch the fuel on, with the lever.

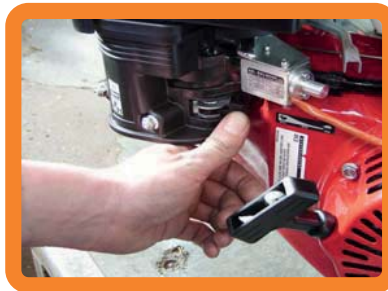

2. With the key, turn the ignition to start, motor on, releasing the starter when the engine fires.



3. Ensure the voltage output matches the appliance intended for use.
4. Connect the flying plug.
5. With the engine running, power will automatically be supplied to the battery charger, and the platform socket. It is possible to operate the machine lift controls with the battery charger switched on.

This machine variant requires a power supply from a fixed source.

Prior to operating the generator, follow these simple guidelines;

- a) Ensure the power supply being attached is the correct voltage.
 - b) Ensure the power supply being used is being supplied via an appropriate power extension.
1. To connect to a mains supply, simply remove the socket's protection cap.



All extensions must be a minimum of 2.5mm², and no longer than 10m, due to possible voltage drop, which will damage the motor.



2. Connect an appropriately rated power extension.

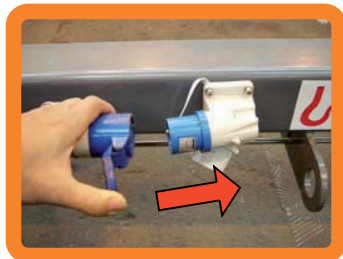

3. Ensure the voltage output matches the appliance intended for use.
4. Ensure that the connection is secure before use.



Blue sockets is 240V output. Yellow sockets is 110V output.



SERVICE MANUAL

Introduction

The Snorkel TL49J, is a versatile means of gaining access in difficult locations.

The access platform is extremely safe in operation providing that basic rules are observed in setting up the machine. This manual focuses on the Maintenance and repair of the machine. Please read the Operators Manual available from Snorkel or from your local distributor prior to operating the machine

All operators and service personnel should have read and understood the Operators manual, and received full training in the safe use of the machine before attempting to use it or carrying out repairs.

Always quote your machine serial number and date of manufacturer when ordering spare parts.

Part number for this manual can be found on the inside front cover.

CONSTRUCTION STANDARDS

The machine complies fully with the requirements of
European Standard EN280 : 2001.

Contents

Technical Characteristics	2
Fault Finding	5
Fault Finding Matrix	7
Notes	14
Maintenance Schedule	15
Maintenance Procedure	17

TECHNICAL CHARACTERISTICS

Trailer / Superstructure / Outriggers.

This consists of a variety of welded and folded fabrications, which, where necessary, contain bushed stainless steel pivots with grease nipples. The main components are shot blasted and then powder coated, and the cylinders are wet painted. The machine also includes fully automatic running gear with auto reverse and also integrated trailer lighting. At the towing end of the machine there is a heavy duty coupling head as well as a pneumatic jockey wheel. The maximum allowable load on the outriggers is 10.3kN and the allowable sideways inclination is 5 degrees.

Equipment

Bottom Ram	Double acting: Bore Ø 60.0 mm Rod Ø 40.0 mm
Top Ram	Double acting: Bore Ø 60.0 mm Rod Ø 40.0 mm
Droptail Ram	Double acting: Bore Ø 60.0 mm Rod Ø 40.0 mm
Stabiliser Ram	Double acting: Bore Ø 70.0 mm Rod Ø 40.0 mm
Basket Levelling Ram	Double acting: Bore Ø 40.0 mm Rod Ø 20.0 mm
Bottom & Top Ram Lock Valves Control Valve (Cage)	Pilot operated over centre valves Monoblock unit consisting of five double acting spools
Control Valve (Ground)	Monoblock unit consisting of four double acting spools
Control Valve (Stabiliser)	Monoblock unit consisting of four double acting spools
Bushes	Acetol resin polymer with sintered bronze base (DX)
Pivot Pins	Stainless Steel Bright Bar To Grade BS970 303 S31 CW
Tyres	215R16C 8 Ply

Power Pack (Battery Power or Mains Power).

Fully integrated power pack consisting of Motor, Pump, Relief valve, non return Check, Return filter with dip stick for checking oil level. Pump is fitted with internal suction strainer. Return filter is fitted with a breather and is used for topping up if oil is required. The tank is fitted with a drain plug on the bottom face. A quick release coupling for checking oil pressure is fitted on top of the pressure port.

Power Pack (I.C. Engine).

Engine is fitted with a separate pump, which is fitted with a return filter and dip stick. Return filter is fitted with a breather and is used for topping up if oil is required. The tank is fitted with a drain plug on the bottom face. The relief valve is mounted independently in close proximity to the pump together with a quick release coupling for checking hydraulic pressure

The engine is fitted with electric start with its own independent start battery. The engine can be started from the engine's start / stop key switch and from the remote start / stop push button fitted in the cage.

Safety Systems.

Full fail-safe hydraulic and electrics as required by EN280 and the Machinery Directive.

Outriggers are pressure sensitive to prevent operating the booms until the outriggers are in full contact with the ground. Outrigger condition is monitored constantly and full visual indication is given by 4 independent LED's mounted on the Ground control panel.

It is not possible to raise the outriggers when the booms are extended. In case of power failure all booms can be lowered and the slew operated using a manual hand pump fitted in the cage. From the ground the top and bottom booms can be lowered manually by actuating the manual override valves fitted to the Bottom and Top cylinders. The slew can be operated by manually turning the slew motor shaft.

The machine carries full CE approval.

TECHNICAL CHARACTERISTICS

Operating Speeds and Noise Level.

Due to oil viscosity and the fluctuating supply of power on a machine fitted with Batteries and / or a I.C. engine as its power source the following nominal operating speeds are indicated. All speeds have been taken with fully charged batteries and at ambient temperature of +10deg. Significant speed differences will be experienced if operating in cold climates and with batteries in a semi discharged state or if the I.C. engine is poorly maintained. All speeds have been taken from the cage with a SWL of 100Kg. Mains power powered machines have different speeds

Drop Nose up	: 18sec	Drop nose down	: 11sec	+/- 1sec
Bottom Boom up	: 40sec	Bottom Boom down	: 22sec	+/- 5sec
Top Boom up	: 24sec	Top Boom down	: 16sec	+/- 5sec
Slew CW 180deg	39 sec	(back) Slew CCW 180deg	: 39sec	+/- 10sec
Basket rotation, from Lock to Lock (90deg) = 6sec +/- 2sec				
Noise Level:	70 db(A) Battery			
	70 db(A) Mains power			
	105 db(A) I.C. Engine			

Duty Cycles.

The mains power pack and the I.C. Engine are both continuously rated. The I.C. Engine speed is fixed and must not be altered.

Battery.

Well maintained batteries will get the following operations from one full charge :

10 lift and lowers with a 5 min brake (to simulate working) at full elevation and when back at ground level + 1 Outrigger raise and lower.....repeated 4 times.

Under normal circumstances this will give the operator a full days work. Connecting the charger to the mains supply, will boost the batteries and give an even longer duty cycle. The machine cannot be directly from the charger, as the current draw from the motor is higher than the output from the charger.

NOTE: The 5 min cooling of the motor is important to prevent motor overload.

It is recommended that fault finding is only carried out by technically competent personnel. Whilst every effort has been made to ensure these procedures are as comprehensive as possible, they will not cover all eventualities.

If difficulty is experienced in identifying a fault, contact Snorkel or their local representative.

1. I.C. Engine will not start (if fitted):
 - A) Fuel in tank?
 - B) Emergency stops are reset (cage & ground controls).
 - C) Engine Ignition switched on
 - D) Start Battery correctly charged
 - E) If engine is cold, has choke been applied (manual) Does the choke pull in (electric).
 - F) Check engine blade fuse (next to engine)

2. DC motor not turning when trying to lower outriggers:
 - A) Key selector switch must be on ground.
 - B) Can you hear contactor on motor clicking ?
 - C) Check battery level / Should be minimum 2/3 charged
 - D) Check motor contactor.
 - E) Check motor brushes.
 - F) Motor fuse
 - G) Check that the emergency stop button has not been activated.

3. DC motor turning but not able to operate outriggers:
 - A) Top boom must be down and boom switch (under top boom, above slew post) activated
 - B) Limit-switch arm must be secure on switch spindle (boom switch)
 - C) Check that diverter valve is de-activated (see hydraulic circuit)
 - D) Check hydraulic pressure / No pressure - Check pump.

4. DC motor not turning - After having lowered all outriggers
 - A) Check key selector switch
 - B) Check that no emergency stop button has accidentally been activated.
 - C) Check outrigger switches - Outriggers must be correctly set.
 - D) Is audible warning in cage "ON" ? - If yes - Check outrigger switches.
 - E) Check 2 - . B), C), D), E).

5. Boom will not raise / lower when control lever is operated and DC motor running
 - A) Correct control station selected, ie ground/platform.
 - B) Check oil level.
 - C) Check that diverter valve is activated (see hydraulic diagram)
 - D) Check that other control valve has all spools in centre position
 - E) Check hydraulic pressure / No pressure - Check pump
 - F) Check that emergency lowering valve is not open (on cylinder)
 - G) Check for obstructions.

FAULT FINDING

6. Audible alarm activated - No boom movements
 - A) You have a light leg. Check level and Limit switch on outriggers
7. Slew will not operate in either direction with DC motor turning
 - A) Check that appropriate control station has been selected,
 - B) Check that machine is on level ground. Slew will not operate if machine is out of level.
 - C) Check for obstructions
 - D) Check that you have not reach the slew stop. 2002 machine specifications will only slew +/-355 deg from the stowed position. Earlier machine would slew +/- 450 deg from the stowed position.
8. Loss of movement on Mains powered machines or I.C. engine powered machines
 - A) Check dump valve. To enable movement the dump valve must pull in to stop oil going to tank
 - B) Check oil pressure.
 - C) Check pump and coupling
9. If Mains motor / I.C. engine stalls when trying to operate machine
 - A) Check relief valve setting
10. If Mains motor stalls when operating machine
 - A) Check for voltage drop.
 - B) Use shorter extension lead
 - C) DO NOT RUN MACHINE - Motor will fail if voltage reading on motor terminals are below 10% of motor rating when motor is running under load.
11. RCD on mains powered machines keeps tripping
 - A) Check for water ingress in terminal boxes.
 - B) Check motor Start & Run capacitors.
12. 0.5A fuse on control circuit keeps popping (Mains Powered Machines) .
 - A) Check coil on selector valve and dump valve for cracks/signs of water damage.
13. Burnt out mains isolating transformer (Mains Powered Machines)
 - A) Check fuse.
 - B) Check coil on selector valve and dump valve for cracks/signs of water damage.

Motor will not start (Petrol)

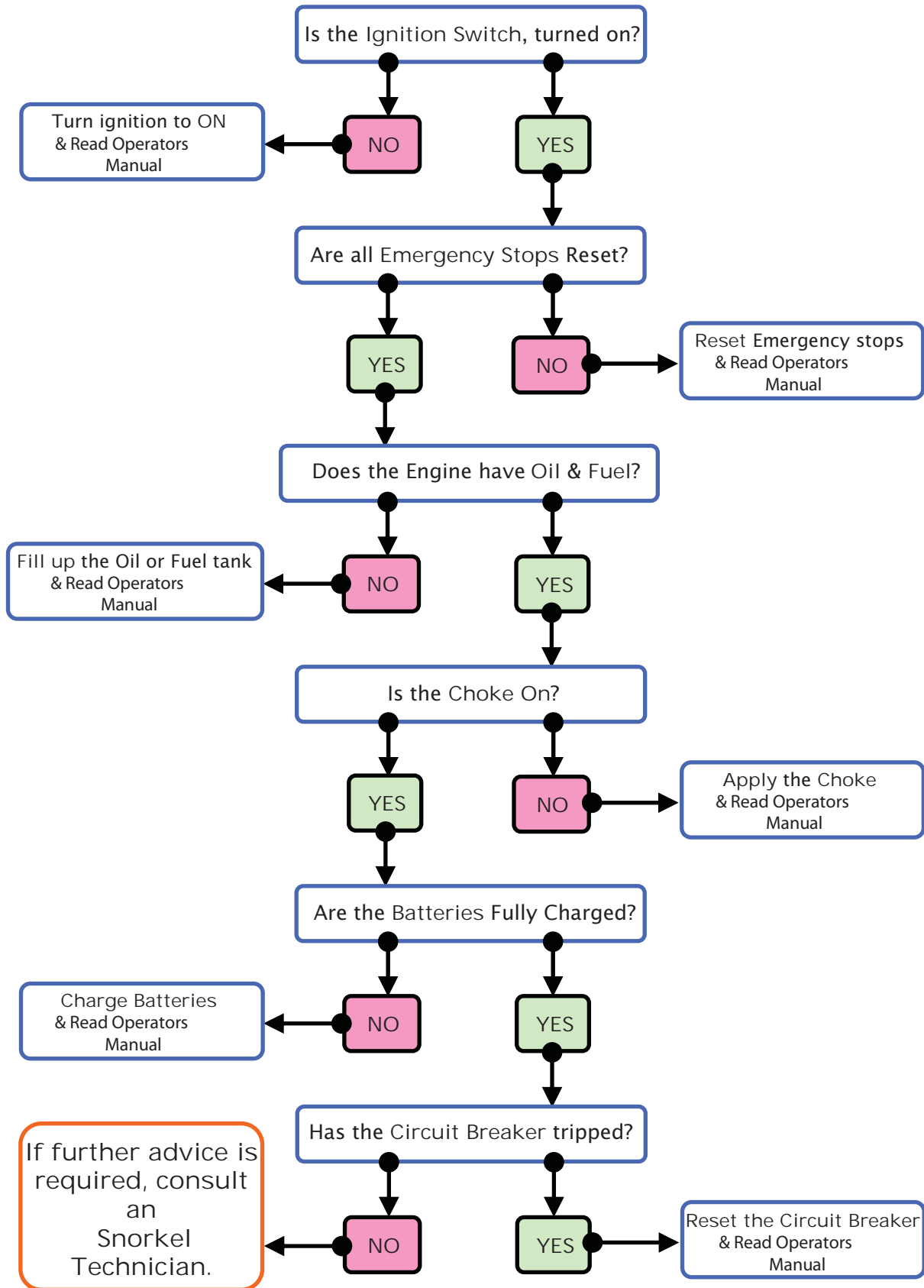

FAULT FINDING MATRIX

Motor will not start (Mains)

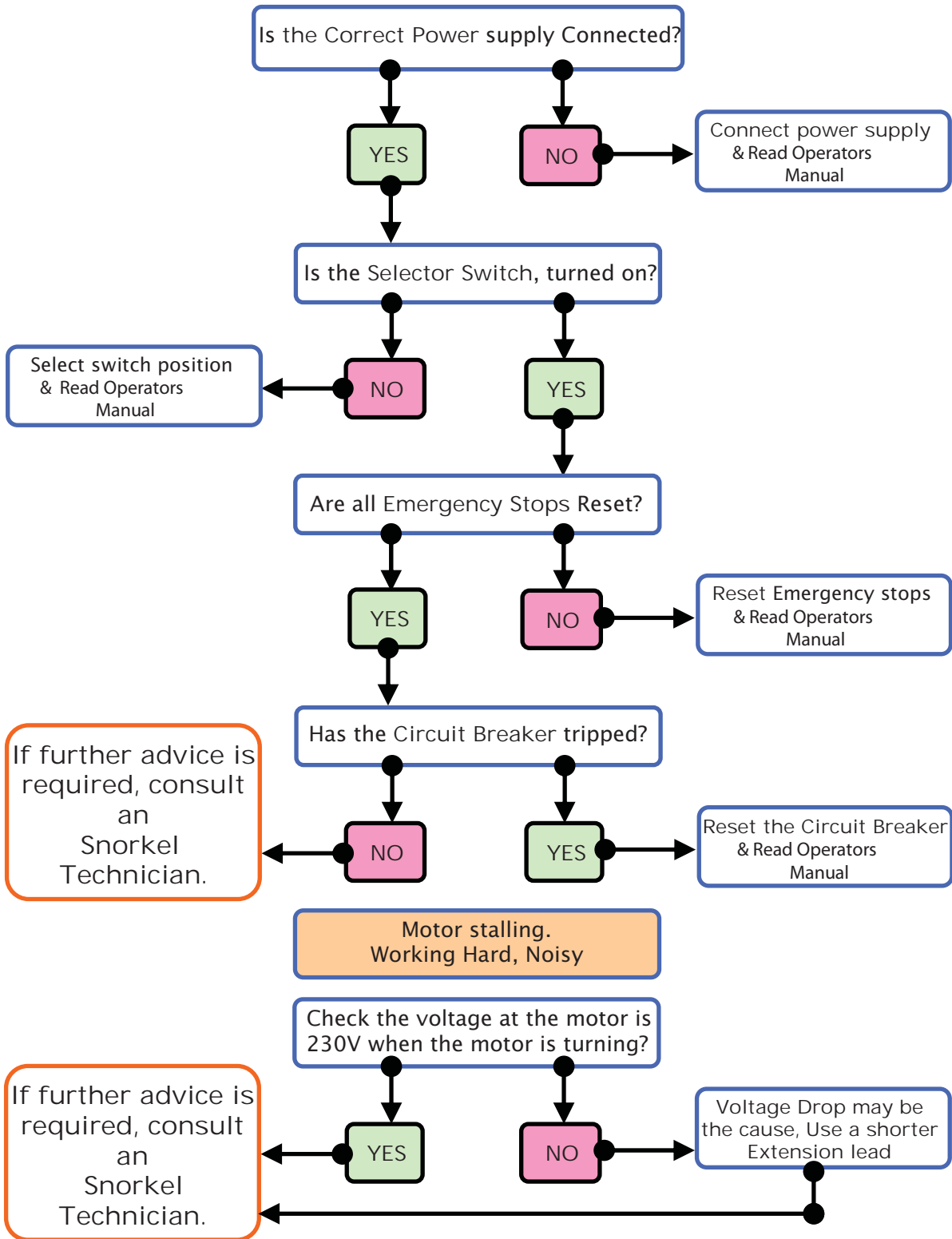

All extensions must be a minimum of 2.5mm², and no longer than 10m, due to possible voltage drop, which will damage the motor.

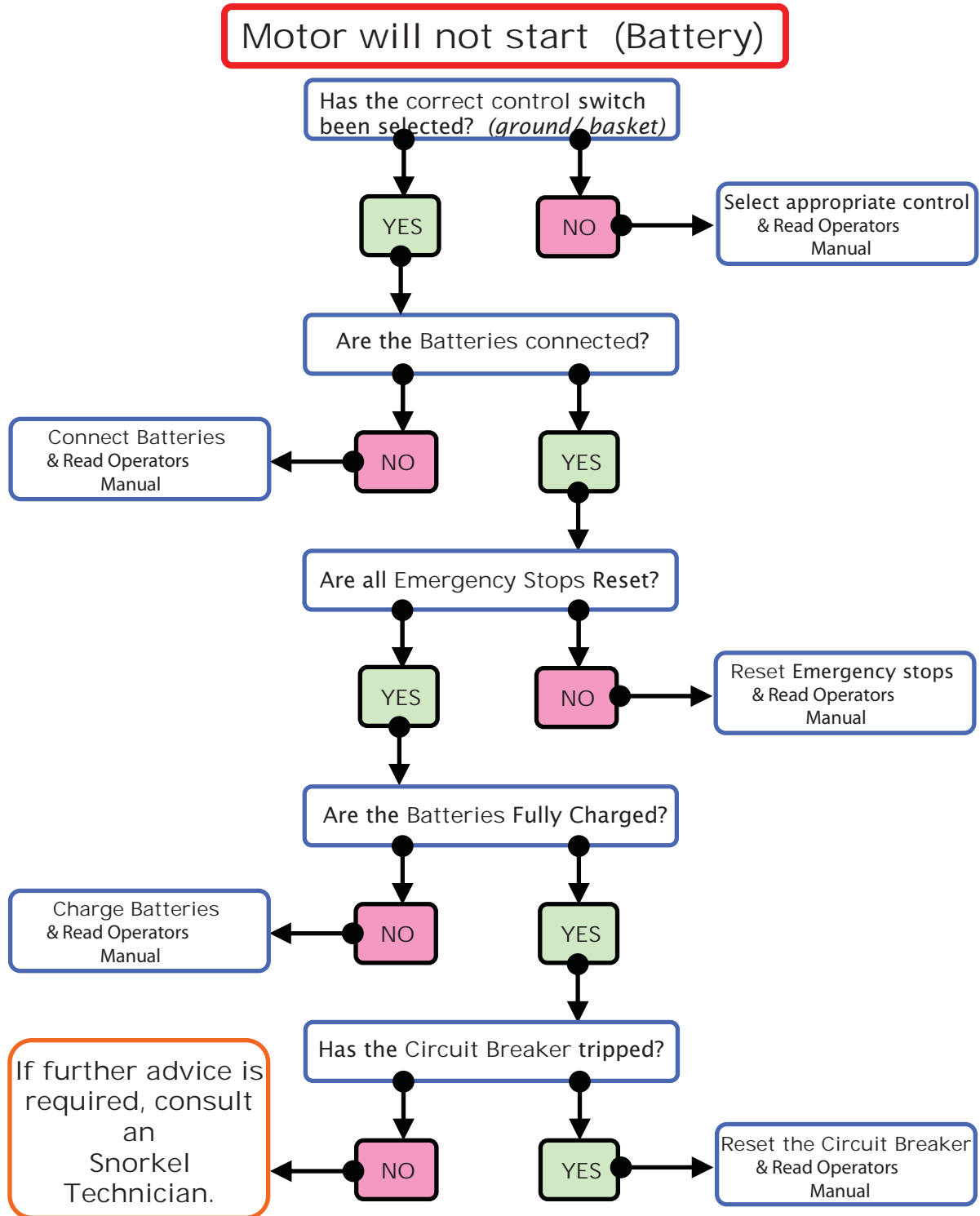

Booms will not raise (Motor Running)

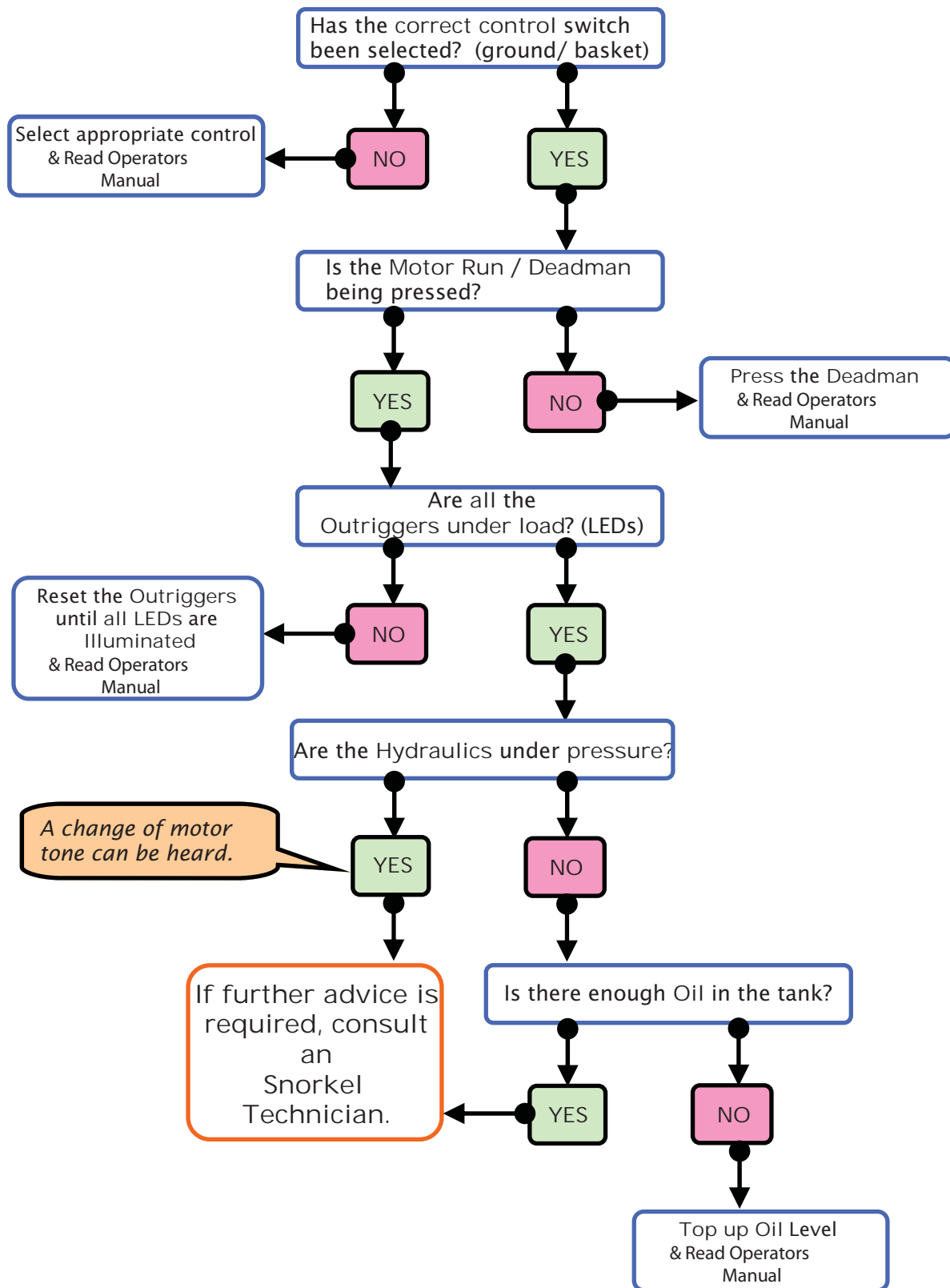

Booms will not lower (Motor Running)

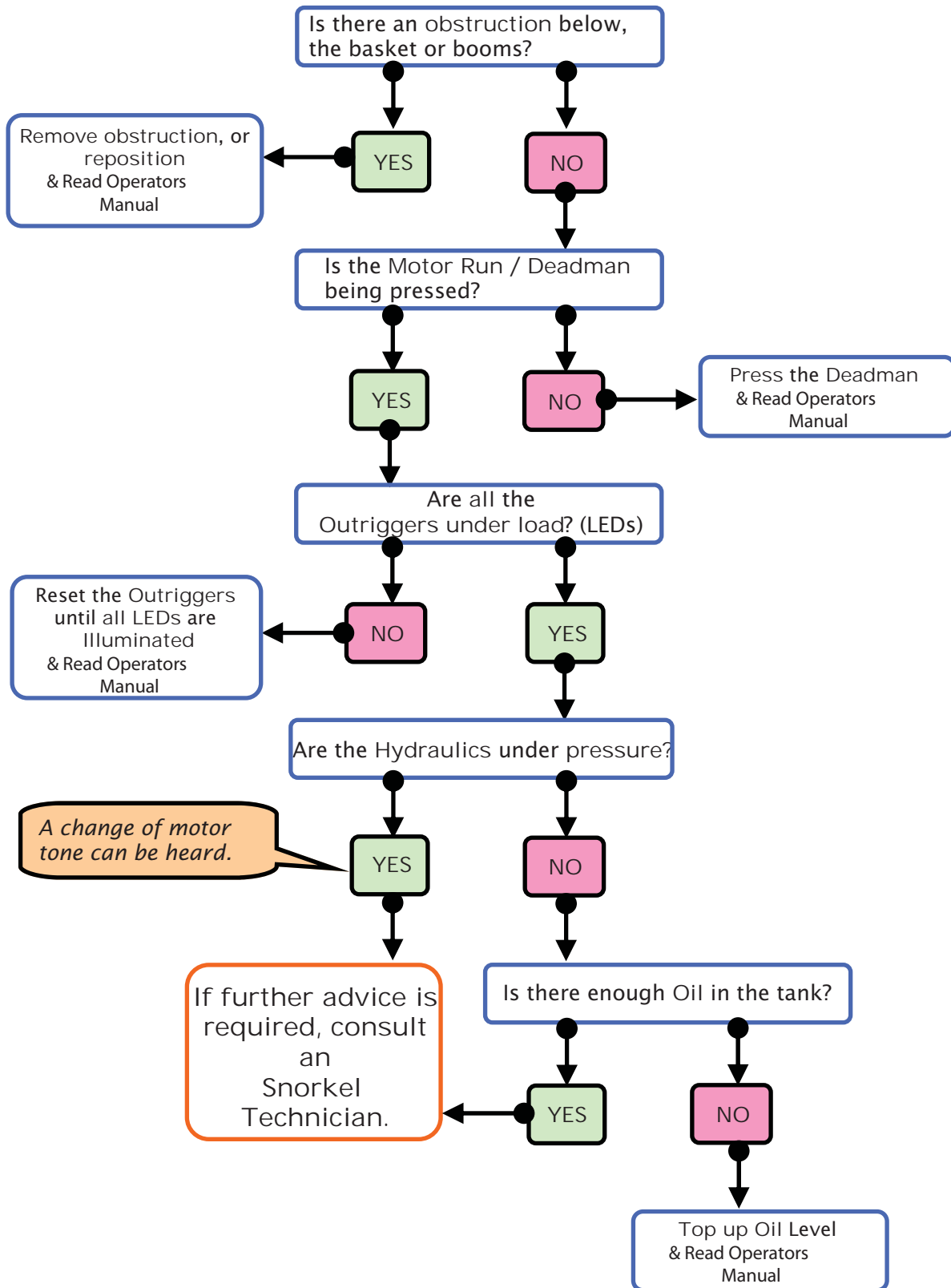

Outriggers will not extend/retract

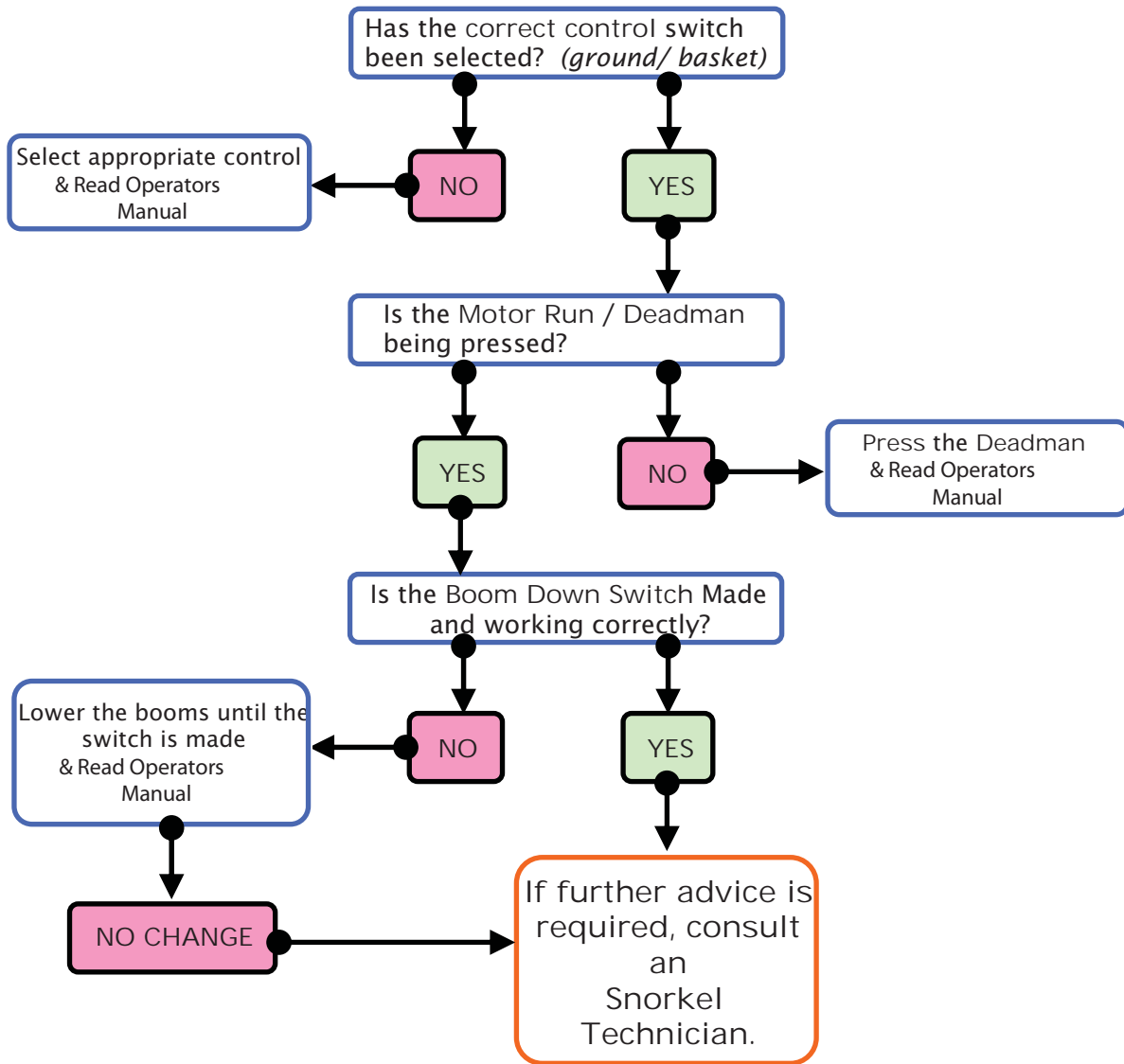

Slew will not operate (Motor Running)

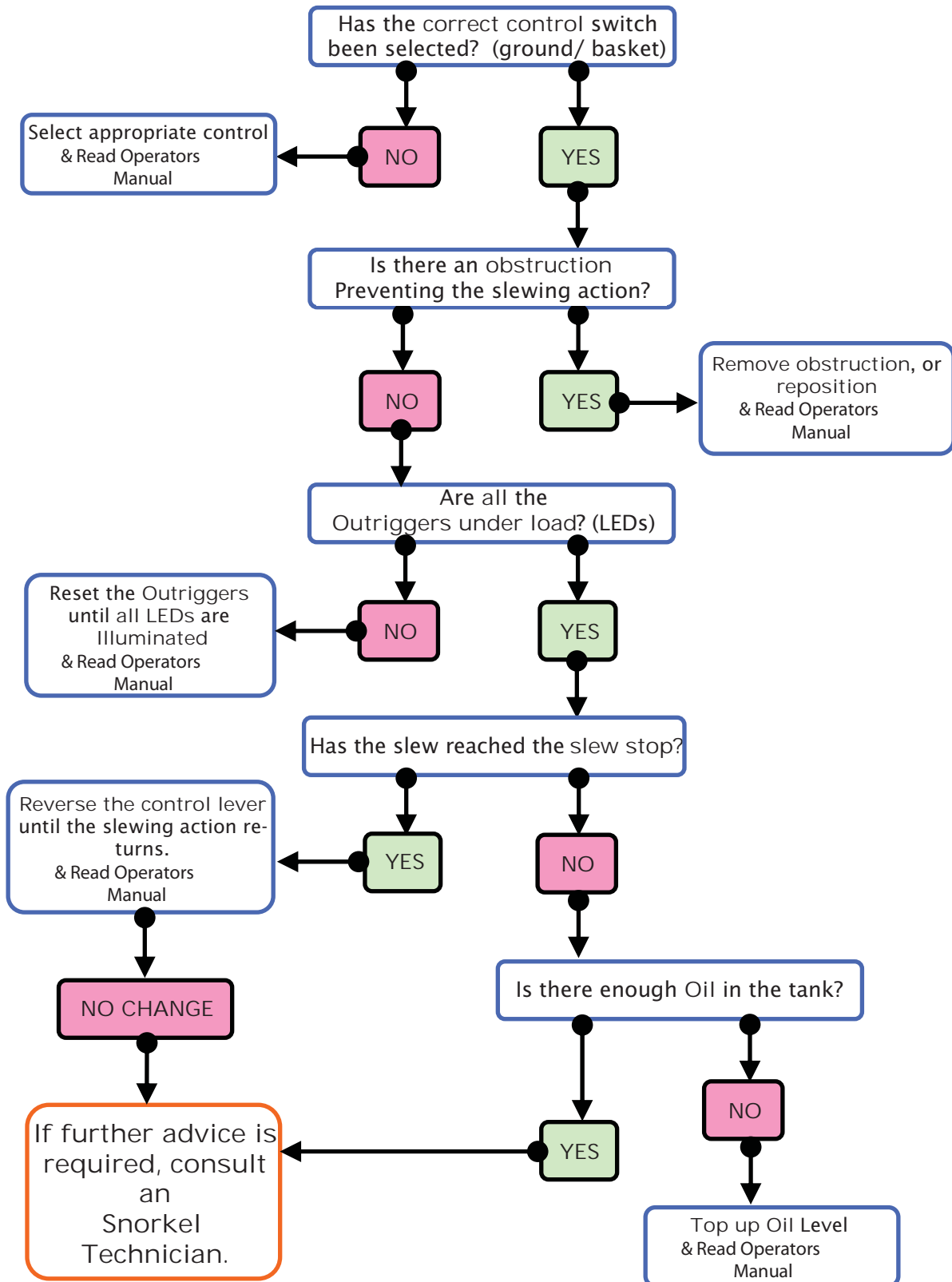

NOTES:

Maintenance.

General - A well maintained machine will give years of trouble free operation. The machine requires very little maintenance. The biggest problem is operators not looking after the machine and physically damaging the structure or its individual components during use or when being towed on the road.

Note - All machines being operated in the UK must have a thorough inspection carried out every 6 months in accordance with LOLER Regulations 1998 and a Certificate of Thorough Inspection produced by a competent person. Contact Snorkel for further details.

Operators Responsibility - It is the operator's responsibility to ensure that the machine is safe to use. To do so, he must carry out all the Daily checks prior to using the machine. From a pure maintenance point of view only the Weekly & 6 monthly maintenance requirement is required. Obviously when the engineer is working on the machine he now becomes the operator and must carry out the Daily checks.

Maintenance Schedule—What is shown here is very much worst case scenario covering most eventualities. If further advice is needed contact Snorkel or its local representative.

The reference number shown on the far left hand side of the table refers to the relevant Maintenance Procedure Sheet in this manual. If this manual was not issued with the machine, check for updates and revisions from Snorkel or its local representative.

- IMPORTANT -

Always ensure the machine is in good, sound, undamaged condition. When carrying out maintenance and repairs always clean the machine thoroughly. Take care not to steam clean the batteries or the electrical components.

Failure to maintain the machine as specified will invalidate your warranty.

MAINTENANCE SCHEDULE

DAILY CHECKS	ACTION	NOTES
Hydraulic System	Top up with machine standing on level ground in the travelling position. Fill oil using the return line filter on top of the tank. Oil must be at the bottom mark on the dipstick. Look for oil leaks.	Use SHF22 oil or equivalent. Change oil and filter every 6 months
I.C. Engine	Check oil, filter and fuel. Check for leaks. Check battery. Top up with distilled water only 6 mm above plates.	See OEM manual for more information
Level Gauge	Check that level gauge is present and secure	
Physical damage	Check for physical damage to the booms, tie bars, basket, slew and the chassis. Check all warning labels are in place	Do not use damaged machine
Nuts, Bolts, Fittings	Check for missing and loose nut and bolts.	Replace immediately
Locking pegs	Check that all locking pegs are present. Check that no shafts are seized.	Broken peg = seized shaft
Transport locks & Lifting points	Check that all transport lock pins are present. Check for damaged lifting points	Do not transport machine without locking pin.
Battery & Charging	If fitted. Check operation of charger. Record specific gravity of each cell. Clean top of battery. Clean and check terminal	
Emergency stop	Check that all emergency stop switches are working	Turn to release
Electrical system	Check for correct operation of the complete electrical system	
Electrical Safety system	Check that you can not operate the booms until outriggers are down and in contact with ground. Check that you can not raise the outriggers with top or bottom boom elevated.	
Hydraulic Safety system	Check that all emergency lowering valves work. Check emergency slew. Check emergency handpump	
Wheels	Check tyres for damage. Wheel nuts and tyre pressure	55PSI 3.8 Bar
Running gear	Check parking brake. Check overrun device. Check for damage	
Trailer lights	Check for correct operation if towing	
WEEKLY CHECKS	Depending on use and operating condition different intervals may be acceptable	
Lubrication	All grease nipples. Depending on machine use and operating condition different intervals may be acceptable.	
Slew Gear	Check slew gear for excessive wear. Grease	
MONTHLY CHECKS	Can be done 6 monthly depending on operating conditions	
DC motor	Check and replace motor brushes if machine is used heavily	2/3 worn = Replace
Wheel bearings	Check for wear - Do checks at every 3000 miles	
6 MONTHLY CHECKS		
Thorough Inspection	Contact Snorkel or its local representative.	Change oil and filter

Power Pack.

The hydraulic system is fully self contained. Oil tank capacity is 15 Litres. When operating above 0 degrees C we recommend using ISO22 Grade Hydraulic Mineral Oil (See Health & Safety guidelines supplied with the oil prior to handling).

Replace oil and filter every 6 months. The biggest cause of hydraulic problem, sticking valves, leaking cylinders etc.. are due to contaminated oil. There is no need to replace the oil in the hoses. Just replace the oil in the tank.

No oil is used by the system so if oil is required this would indicate an oil leak which must be investigated prior to using the machine.

Correct Oil Level.

It is critical that the correct oil level is maintained. Too little oil will cause cavitation and failure of the pump. Too much oil will lead to oil leak through the return filter breather or a massive oil leak when using the emergency lower valves on the top and bottom boom. The rams are double acting. When using the emergency lower valves you require free space in the tank to accommodate oil which normally would be pumped into the annular side of the cylinder. If this should happen, just clean up the oil spillage. Fully extend ALL rams. Then close up all rams and check the free space in the tank using the dip stick. Oil must be at the bottom mark on the dipstick to ensure correct level.

DC Motor & Pump.

The hydraulic pump is submerged in the tank. Oil is drawn in through a suction strainer protecting the pump. The DC motor (shown) is directly coupled to the pump shaft. On AC motor a small adapter coupling is used between the motor and pump shaft. To replace the pump the tank must be removed. Remove the power pack from the machine. The tank is secured with 4 bolt. Remove the tank. The pump is bolted to the aluminium block containing the relief valve (Hidden under the red cap shown here - Relief valve is factory set to 210Bar). Remove the 4 fixing bolts securing the pump.

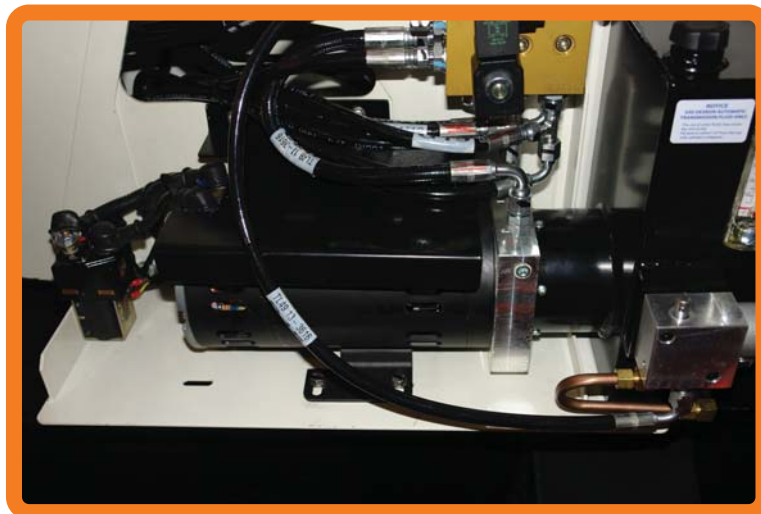

MAINTENANCE PROCEDURE

When the pump has been removed it can be split and the gears can be inspected for wear. If the gears are worn (or broken) we recommend replacing the complete pump. The replacement pump is complete with gears, front and back plate all ready to bolt on in place of the old unit (strainer is not included). Before fitting the pump, apply a liberal amount of clean hydraulic oil to the gears. Take great care to torque the 4 - 5/16 Hex fixing bolts evenly to 13 ft/lbs to ensure correct operation of the pump. **DO NOT OVERTIGHTEN**. Before fitting the tank. Thoroughly clean the tank and the magnet you will find inside the tank. De-grease, replace the large "O" ring and apply a small amount of silicone around the circumference of the de-greased tank neck. Push the tank back on and secure with the 4 bolts removed earlier.

DC Motor.

DC motor - The DC motor can be removed without worrying about oil spillage. Remove the 2 long bolts at the end of the motor. You can now withdraw the motor. Take care not to strain the wires.

To ensure optimum performance from the DC motor we recommend replacing the motor brushes when they are 2/3 worn. If the machine is used extensively (quite normal in a hire environment) this can be required at least every 6 months. To replace the brushes, fully remove the motor from the power pack. Blow out all the brush dust using compressed air before reassembling the motor.

Check the motor shaft bearing and replace if worn. We also recommend replacing the contactor at the same time as replacing the brushes. The unit is fully sealed (to prevent sparks igniting battery gases) and contain no serviceable parts.

If the motor is not stopping when the green motor run button is released, and no power is at the contactor coil, replace contactor immediately. To stop the motor in this case. Use the battery disconnect plug or lightly tap the contactor on its end (1) with the handle of a large screw driver to free the internal contact points



IMPORTANT

The main relief valve is factory set at 210 bar and should normally not need adjusting. Breaking the seal (3) during the warranty period, for whatever reason, will invalidate the warranty.

Power Pack

Fully integrated pump, tank, preset relief valve and return filter. The biggest cause of hydraulic problems is down to contaminated oil. Change oil and filter at least every 6 months, even though the hydraulic system is a closed system. The only access for external dirt is through the filter breather. You will have contamination due to seal kit wear (black sludge in the bottom of the tank, mechanical wear from the gear pump, valve block and cartridges in addition to water contamination due to tank condensation. See power pack section for more details.

SOL1

This valve diverts oil from the outrigger control valve first to the ground control valve and then to the basket control valve. Never operate the coil unless it is on the valve cartridge. You risk burning out the coil.

Ground Control Valve

This gives you full control over all functions apart from the basket slew. The adjustable relief valve is set at the factory to approximately 190 bar. It should be set so that when you lift the bottom boom from rest you can just lift the full safe working load (SWL). The centre position is closed to prevent oil back feeding and running back to tank when operating the basket controls.

Slew Motor

The slew motor is bolted directly on the slew gear. Apart from greasing and checking for oil leaks it requires no maintenance.

Platform Controls

Is identical to the ground control apart from the extra valve bank needed to control the slewing basket ram. The orifice in the Basket slew fitting is there to prevent the basket turning too quickly.

Hand Pump

Enables you to lower and operate the slew in case of emergency. The pump is fed from the general return line. It is theoretically possible to extend the cylinder with the hand pump but the force required is excessive and the fixing bracket for the hand pump is not designed to take such a load. If no resistance is felt when operating the hand pump try to operate the basket slew or the drop nose to prime the pump.

Basket Slew

Cylinder has no lock valve. It relies on the closed centre of the spool to prevent it moving.

All Other Boom Cylinders

Have lock valves fitted to prevent uncontrolled movement in case of hose failure.

Stabiliser Control Valve

In the centre position, this block has the B port connected to the tank. This is to ensure that the outrigger cylinder check valve closes quickly when setting up the machine. The 4 restrictors shown are there to prevent cylinder juddering caused by the check valves fitted to the outrigger cylinders.

MAINTENANCE PROCEDURE

Read this in conjunction with the description of the hydraulic circuit (31HC20A) for the Battery 24VDC powered machine.

The TL49J can be fitted with a variety of power options. The battery powered machine has only one solenoid valve fitted (SOL1). Both the I.C. engine and the mains powered version have a separate dump valve fitted (SOL2). This is because oil is in circulation all the time, not only just when a cylinder movement is required as on the battery version. Having oil circulating through the different valve blocks may lead to uncontrolled movements should the controls accidentally be operated. By fitting a dump valve the oil will always go to tank unless the dump valve is activated.

See the relevant circuit diagram for your machine at the end of this handbook or contact UpRight or its local representative for further information if required

TOP & BOTTOM RAM

Each ram is fitted with a manual release to enable lowering of the boom in case of emergency. Depress the red button and hold. When released, the red button will spring out and the movement should stop.

If the cylinder is operating erratically - Jamming at odd intervals with the motor running. - Check that the little restrictor disc (1) fitted at the nose of the cartridge has not come loose. The disc is held in place with a small circlip. Replace cartridge.

The O/C valve enables the oil to flow freely into the cylinder but will not let any oil flow out until a pilot signal is received when pumping oil into the annular side of the ram. The O/C valve will then open up and let oil flow out, in a controlled manner, to prevent boom juddering.

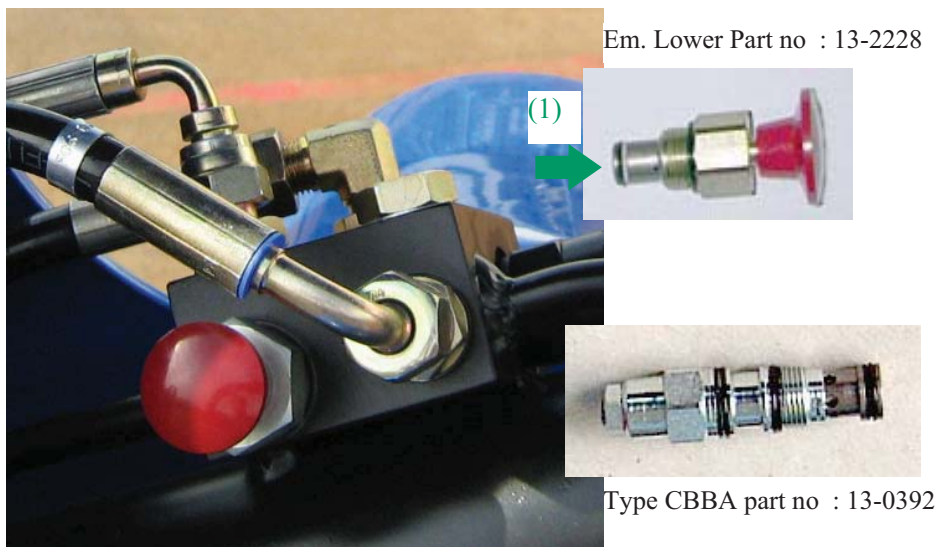

The O/C valve is also fitted with an adjustable relief valve which must be set to 1.25 times the maximum pressure inside the cylinder. If the cartridge is marked with CBBA you screw the adjusting screw CCW to increase pressure. If screwed fully CW the cartridge is now fully open and does not hold any load. The O/C valve must be set correctly to ensure safe operation.

Ram not holding under load.

When you let go of the controls the cylinder movement must stop.

We do not advise that a machine is left extended unattended for any great length of time (over night etc.) It is normal to expect some slight creep over time, but during normal operating conditions the ram should hold the load and not move once the lock valve cartridge has closed. (This may take up to 1-2 sec after the directional valve has been returned to the centre position. The pilot pressure holding the valve open must be allowed to drain back to tank to allow the lock valve to seat fully).

When a cylinder is not holding you must decide which part has failed.

- Cylinder Piston Seal
- O/C valve (or check valve)
- Emergency Lowering cartridge (if fitted)

The best and quickest way of establishing this are by removing all hoses (carefully) to see where oil is leaking out.

If oil is coming out from :

- The Emergency lowering cartridge is faulty. Clean or replace
- The O/C (or check valve) is faulty. Clean, adjust relief valve or replace (Note that check valves are non adjustable and can only be cleaned or replaced)
- Replace the Piston seal kit. Oil is passing the piston and escaping out of the annular port which have no lock valve fitted

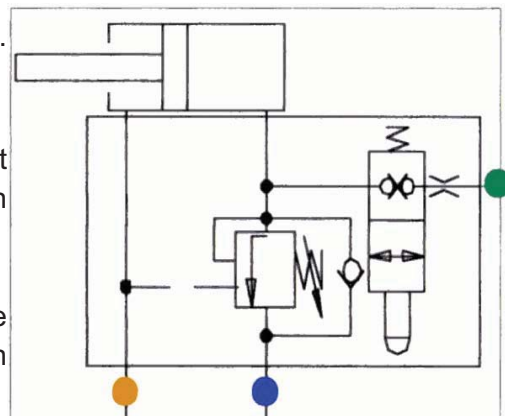

For clarity the drawing shows only one hose to each service. In reality you have two hoses, one for the Cage controls and one for the ground controls. It is only the emergency lower which has one hose.

MAINTENANCE PROCEDURE

DROPNOSE RAM

Is fitted with two O/C valves. You have two things you can try to help you to decide which component has failed :

First remove all hoses (take care) so you can see where oil is escaping

- If the oil is escaping from the full bore side the full bore O/C valve is the problem.
- Slowly open the adjusting screw for the O/C relief valve on the annular side. The piston seals have failed if oil starts to come out from the annular side and the cylinder is starting to close up at an increased speed, replace the piston seals

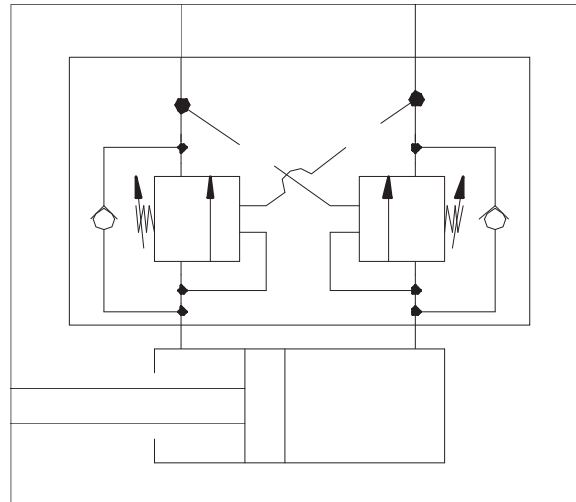

Dropnose cylinder with welded on block containing two adjustable O/C valves

OUTRIGGER RAM

Is fitted with two check valves. They have no adjustment.

If the outrigger is not holding under load it is most likely that the check valve for the full bore side is leaking.

The check valves are difficult to get to as the block is well protected from falling objects by being tucked well away on the underside of the ram. You have to remove the rod pin from the outrigger when the outrigger is retracted.

You can now swing down the outrigger to free the cylinder.

Both check valves are identical. You can swap them over to see if the cylinder stop moving.

Remember the • full bore check ensures that the outrigger stays down when you are up in the air working. The annular • side check ensures that the outrigger remains vertical when you are towing the machine down the road.

The • restrictor is critical to prevent the outrigger juddering when raising the outrigger to the transport position. Do not replace with a non restricted hose adapter.

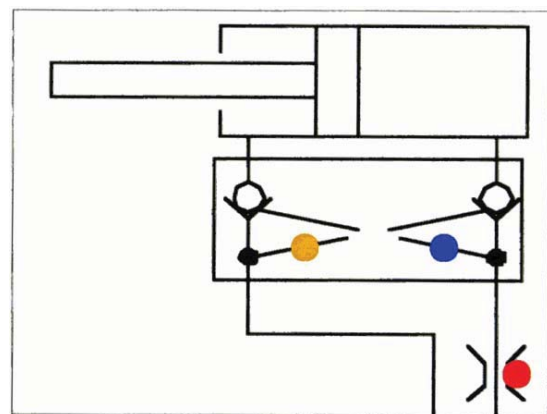
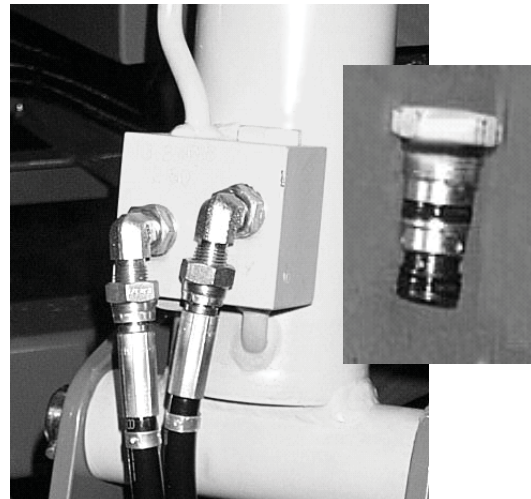

Outrigger cylinder with welded on block containing the two check valves. The restrictor shown is the hose adapter fitted in the outrigger control valve

CONTROL VALVE - CAGE

The relief valve is set at 190 Bar and should be adjusted in accordance with the setting up procedure.

Remove cap and screw adjusting screw in to increase pressure and out to decrease pressure. Put cap back after adjusting.



The diagram below with the manual hand pump on the left hand side.

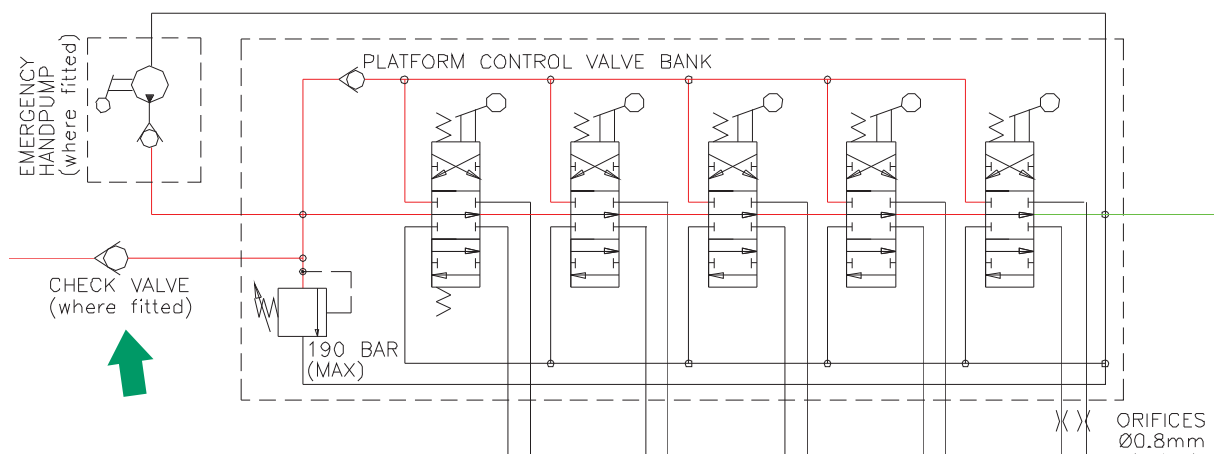

All spools used are the same. They are all closed centre in the neutral position. It is critical that the valve block does not leak internally when in the neutral position. Remember you have two valve blocks. Each is connected together at the lift cylinders.

If the Ground valve is not leak free, with the spool in the neutral position, when operating the Cage valve, the oil will not go into the cylinder but leak out (internally) through the Ground valve. This can also happen if the spool is not properly centralised by the spring at the end of the spool.

The same thing applies if you operate the Ground controls and the Cage valve is leaking internally.

The normal symptom for this problem is when the operator reports that *“everything works fine from the ground controls but when operating from the cage, boom x does not move. Motor runs but nothing happens.”* This indicates that the valve which operates the boom is the valve which is faulty.

MAINTENANCE PROCEDURE

CONTROL VALVE - GROUND

Is identical to the cage control valve apart from the following:

- Only 4 sections. Unable to operate the slewing basket from the ground. The slewing basket is the last spool shown on the cage valve drawing with the two restrictors.
- A high pressure carry over plug has been fitted to the ground control valve to allow oil under full system pressure to pass through it. Without the internal plug you will not be able to operate the basket valve as all oil would go directly back to tank.

If you have to replace the ground control valve make sure the carry over plug is fitted. The plug is inside the valve, under the fitting for the return line. Shine a light down the port and you will see the Allen head grub screw. If it is not there, use the grub screw fitted to the valve being replaced.

An oil leak from the valve block it is likely to be from the end cap.

Either the end where the lever is or at the opposite end where the return spring is. Never fully withdraw the spool, push it out opposite to where the leak is coming from sufficient to clear the "O" ring. Now can pry out with a small screw driver. Put plenty of grease and keep well lubricated when pushing the spool back in.

If the spool is not centring check that the return spring and the end cap is well secured.

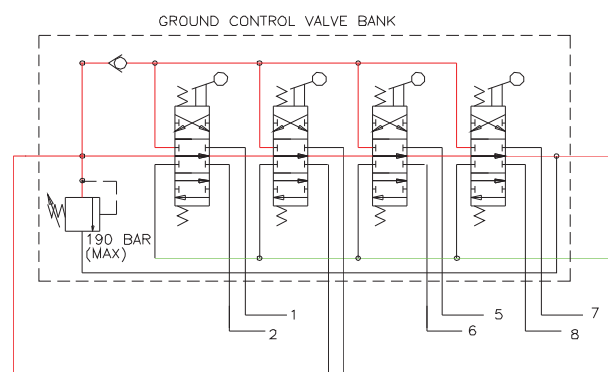

DIVERTER VALVE

When not activated (no power on the coil) The oil will flow as indicated by the symbols left hand side.

When activated the oil will flow as shown on the right hand side.

When you look at the complete circuit you will see that with no power on the coil., oil will flow to the outrigger control valve. Activate the valve and oil flows to the ground control valve. If you do not get full flow, or you get a high pressure drop over the valve, you may have a sticking valve . Remove the cartridge form the aluminium body and clean. Also look for contamination in the valve or the valve cavity.

To check that power is reaching the coil you can hold a screwdriver against the end of the coil. When the coil is activated you will feel a strong magnetic force pulling the screwdriver towards the nut securing the coil to the cartridge.

Do not use great force when securing the coil to the cartridge as the casing can easily crack due to thermal expansion when it is heated up during use.

The coil will fail if water gets in through the crack.

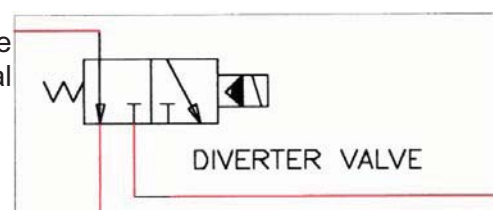

OUTRIGGER CONTROL VALVE

This valve is not interchangeable with the ground control valve even though it is a 4 bank valve block with a relief valve and looks identical to the ground controls.

When the spool is in the neutral position the annular side of the ram is attached to the tank line. This is done to ensure that the pilot pressure holding the check valve on the full bore open, is drained off quickly to tank so that the check valve close quickly

If the valve block is replaced make sure that the piping is done exactly as shown. You rely on the closed port as your back up for the check on the full bore side.

Some early version did not have this type of spool. This type can easily be identified as it has Din-Oil stamped on the end cap. This type used a standard closed centre valve block. The leakage rate across the closed centre spool was high enough to ensure that the check would close

Each A port has a restrictive hose adapter fitted in the valve block. If the restrictor gets blocked you will not be able to operate the cylinder correctly.

When looking for a fault relating to cylinders and valve blocks - swapping hose connection can easily give a good pointer to where the fault is. If the fault stays put, you know that the fault is in the valve block. If the fault moves you know it is the cylinder. Do not over tighten the hose fitting. You are more likely to cause a leak by deforming the adapter cone than leaving the fitting to loose.

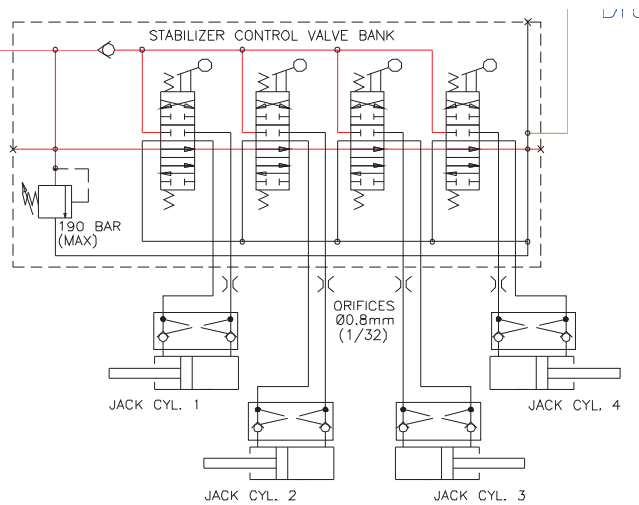

RESTRICTORS

You have seen that all valve blocks have restrictors fitted at different locations. The most common version on the current versions (2002) of the TL49K uses a hose adapter with a drilled hole. Other types which have been in use (and still are on other machines) is a simple copper washer with a sized hole. The copper washer is squashed between the hose fitting and the adapter screwed into the valve block.

It is easy to see when a copper washer type restrictor have been used as it looks like the hose fitting is not screwed fully down onto the adapter when comparing to the hose fitting next to it. You also need more force when tightening the hose fitting to prevent leaks



Hose adapter shown here with drilled hole. If cylinder movement is erratic check for contamination



Copper restrictor fitted loose in the hose adapter. Hose end require more torque to prevent oil leak when securing hose.

MAINTENANCE PROCEDURE

SLEW MOTOR

The motor is a high torque low speed hydraulic motor. The motor can be unbolted from the slew drive to check for leakage. Full seal kit is available with overhaul instructions.

3 and 4 indicate the hoses going to the cage controls.

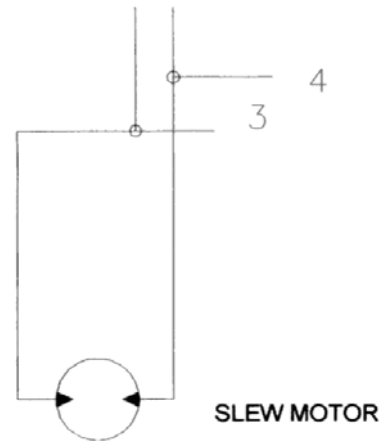

GENERAL TESTS OF LOAD HOLDING VALVES

You have seen that all critical movements rely on 2 components for safety

- The lock valve on the cylinder
- The closed centre on the valve block

The valve blocks used have very low leakage rate (that is why we can rely on it for the slewing cage ram which have no lock valve).

How do you know if you are holding on the valve block and not on the cylinder lock valve ?

With the pump not running. operate the valve block as if you were going to close the ram up. If there is cylinder movement there is a leaking load holding valve on the cylinder.

Do not use a machine where the load holding valve has failed.

BLEEDING

The hydraulic system needs no special bleeding. Having stripped a cylinder down or removed hoses for repair, operate the cylinder fully in and fully out and the system is operational.

SLEWING CAGE RAM

Do not operate the slewing basket ram valve lever without the pump turning. If you operate the valve lever you can push the basket from side to side. You have now entered air into the system and the basket will not stay put during transport.

If this should happen, just move the valve lever with the pump running, moving the basket from side to side will fill the cylinder with oil and the basket will lock in place, when you release the lever

Warning

Keep it clean - Replace filter and oil regularly - Make sure the oil you put in the tank is clean - Never fill oil using dirty cans - Remember you use no oil - If you have to replace oil you have a leak - If you work regularly below 0 deg C and use low viscosity oil, do not forget to replace the oil for regular grade in the summer to prevent oil leaks from cylinders and hose ends - Keep a log of relief valve settings to monitor pump performance - If you have a problem the first thing to do when you arrive is to fit a pressure gauge to see what is going on. Do not rely on the sound of the pump !

HYDRAULIC PUMP

The engine is driving a hydraulic pump via a spider type coupling.

What to do if loss of oil pressure is experienced and the motor is running correctly?

First check that the hydraulic system is working correctly by checking that the dump valve is activated. If the dump valve is working and you still have no oil flow, it is most likely to be a failed pump or that the coupling is spinning on the motor or pump shaft. Remove the bell housing to check that each coupling half is secured on the shaft. Then remove the pump and check the internal gears. The Stop/Run/Start key switch is located on the right hand side of the engine. You also have a separate push button Start/Stop in the cage. Some engines are equipped with an automatic electrical choke to facilitate remote cold start.

For the engine to start remotely, the key switch on the engine must be in the run position. If not, the engine will turn over on the starter, but will fail to ignite. The platform's control circuit is powered by the engines start battery. The built in heavy duty 10A alternator will recharge the battery during use. If the engine is not turning over when trying to start the most likely cause is a discharged battery. Jump start using another 12 volt battery or use the manual recoil fitted on all engines. Always switch the key switch on the engine to the "Off" position when not in use to isolate the circuit.

Should the engine turn over without starting check the fuel level first ! Then look at the electrical circuit for faults.

Always let the engine reach operating temperature before loading the hydraulic circuit.

Some engines are fitted with a low oil level safety cut out which will stop the engine and prevents starting if the oil level is low.

The engine Stop/Run/Start key switch must be in the run position even when starting the engine manually.

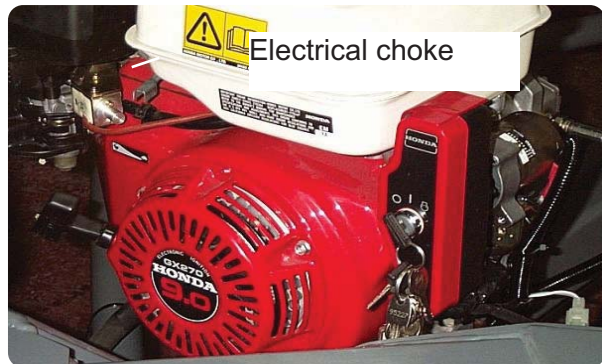

- HP: 9HP / 3600RPM Max torque 2600RPM
- Fuel Capacity : 6 Litres
- Pump Capacity : 1.19 cc
- Operating RPM : Set to boom speeds !
- Noise level : 75db (A)
- Max Charging current : 10A
- Battery required for manual start : NO
- Battery required for platform electrics : YES
- Max running time (approximately) : 8 hours
- Low oil level cut out fitted : YES
- Engine oil spec: SAE 10-40

Check battery weekly and top up with distilled water if required

See OEM manual for more information.

MAINTENANCE PROCEDURE

ENGINE SETTINGS

The throttle is locked and must not be tampered with. If the boom speeds are not in accordance with the time test sheet the engine speed may have to be adjusted. Set engine speed by adjusting the throttle to give required pump flow which in turn governs boom speed. Then set throttle end stop and secure throttle from turning using lock nut on throttle spindle (not shown)

Use fuel cut-off when moving machine over long distances.

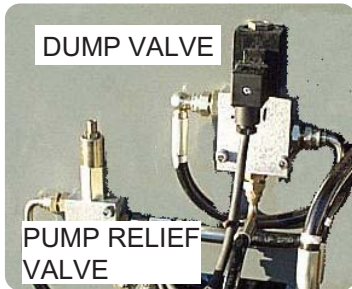
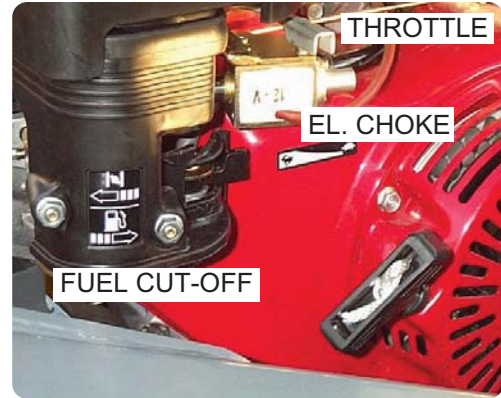

ELECTRICAL START / STOP

The full engine electrical diagram below is not integrated in the main electrical diagram for the machine. The engine is stopped by letting the signal to the ignition coil go to earth.

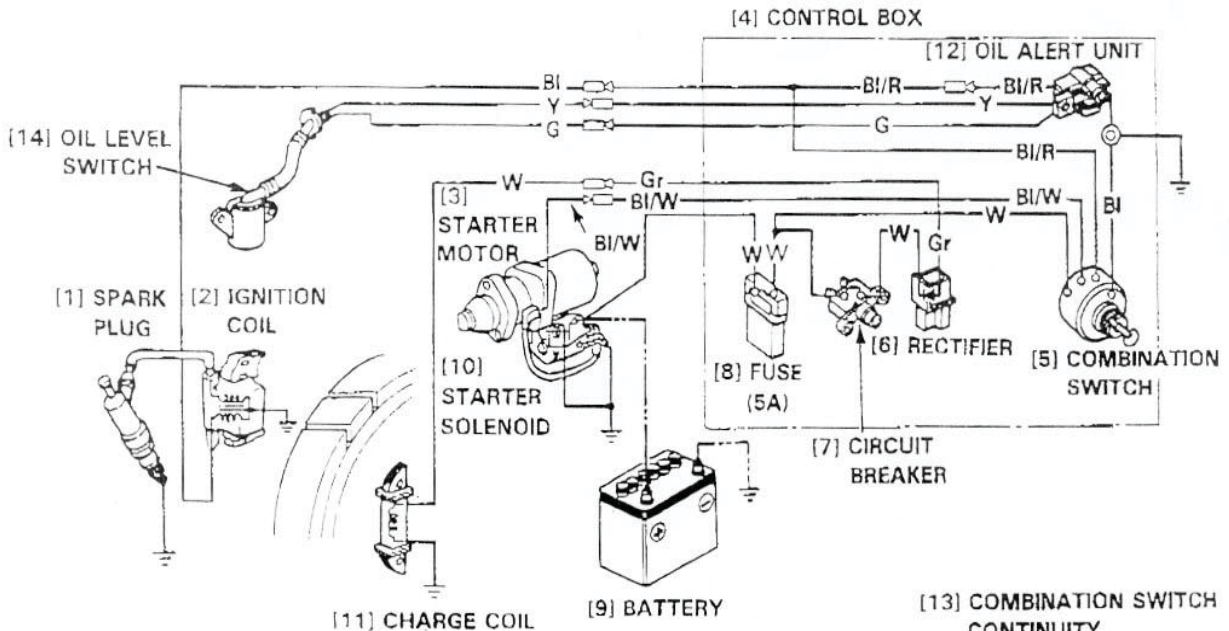

Bl	BLACK	Br	BROWN
Y	YELLOW	O	ORANGE
Bu	BLUE	Lb	LIGHT BLUE
G	GREEN	Lg	LIGHT GREEN
R	RED	P	PINK
W	WHITE	Gr	GRAY

	IG	E	BAT	ST
COLO	B/R	Bl	W	Bl/W
OFF	○—○			
ON				
START			○—○	

LEVEL GAUGE

The level gauge used for setting up the machine is located next to the outrigger control valve block. If the level is damaged or has been removed do not use the machine until a new level has been fitted.



PHYSICAL DAMAGE

When looking for physical damage it is important that the machine is clean. Large dents in the boom from operators hitting obstacles are generally easy to see. Crack in welds or corrosion damage can be harder to spot. The biggest wear and tear is not the load in the basket but the constant vibration from towing. Curbs and Speed Bumps passed at high speed can cause severe damage to the tow bar or the axle.

On machines fitted with the optional sliding axle inspect the underside of the axle carrier and the sliding box suspension. On machine fitted with the fixed axle check the fixing bolts and the main chassis member. Also check the area just behind the coupling where the vertical boom is secured to the towbar. If someone has forgotten to secure the vertical boom to the towbar and towed the machine over a long distance on poor roads damage may have occurred due to the constant banging of the vertical boom against the towbar. Also check the top boom rest. The top boom must also be locked in place during transport.

IMPORTANT

The top boom lock is strictly speaking not needed if the operator always fully lowers the top boom and powers it down in the rest position. Unfortunately experience on earlier machines has shown that the operator would forget to fully lower the boom and damage would occur to the underside of the top boom when it bounced about in its rest during transport. Fitting the top boom lock greatly reduces the need for top boom repair or possible replacement.

Another area prone to damage is the drop nose. When reversing, the basket may hit a low wall or a post. The impact may not be easy to spot on an already battered basket but the impact may bend the bottom of the dropnose.

Check the straightness of the top tie bar. A slight dip is acceptable but a pronounced kink or sideways bend is unacceptable. Check both booms for creases in the steel next to the main bosses next to the slew post and the vertical boom.

Hoses and cables are prone to damage and wear and tear. If the outer sheathing on the hydraulic hose is slightly frayed fitting a temporary outer sleeve may be adequate depending on the size of the damage.

IMPORTANT

Always think of **SAFETY FIRST** and err on the side of caution -
If in doubt replace, or ask **Snorkel** or its local representative for advice .

NUTS & BOLTS

Replace any missing bolts immediately. The main pivot shafts and pivot pins are secured with one or two locking pegs. The locking peg not only secures the shafts from falling out but also stops them turning.

Most nuts used are Nyloc nuts which are superior to the normal full nut and spring washer. Never use plain nuts and spring washers unless originally fitted . Always torque fixings.

THREAD SIZE	MAXIMUM TIGHTENING TORQUES			
	UNPLATED		PLATED	
	Nm	Lbf.in.	Nm	Lbf.in.
M4	4.6	40.7	3.5	31
M5	9.5	84.1	7.1	62.8
M6	16.0	142.0	12.0	106.0
M8	39.0	345.0	29.0	257.0
M10	77.0	682.0	58.0	513.0
M12	135.0	1200.0	101.0	894.0
M14	215.0	1900.0	161.0	1420.0
M16	330.0	2920.0	248.0	2190.0
M20	650.0	5750.0	488.0	4320.0

MAINTENANCE PROCEDURE

LOCKING PEG

Each shaft is secured with a locking peg as mentioned above. If you find that a peg is broken or that the bolt and peg is missing then this can be a sign that the shaft is seized due to lack of lubrication. If a seized shaft is suspected, check that the x-drilling for the locking peg lines up with the bolt hole for the locking peg securing bolt. Fit a new peg. Carefully operate the boom to see if the shaft is trying to turn.

If a grease nipple is fitted, apply grease. If you suspect that the shaft is seized it is recommended to drive the shaft 1/2 way out. Clean and apply new grease. If the shaft is badly worn or scored, replace both shaft and the bush.

Depending on which shaft is causing the problem, you may have to support the structure to prevent jamming when extracting the shaft.



LOCKING PINS

It is important that the boom locking pins are used when the machine is transported. Never transport a machine if the pin is missing. The fixing clips fitted on current (2002) machines have been provided to prevent paint damage by the pin hitting the structure during use.



When towing, insert pin and lock in place with the "R" clip provided. During inspection look for indication of the machine being moved without the pin. Good tell tale signs are dents in the top boom and crack lines below the vertical boom. Contact UpRight or its local agent on advice for repairs.



TIE DOWN LUGS

Check for wear and tear. Check for damage. You have two lugs attached to each side of the outriggers. Earlier models had “A” frame towbar with one individual lug welded to each side of the towbar.



NOTE:

The lugs are for securing the platform when being stowed or transported, and are NOT designed for lifting the access platform.

MAINTENANCE PROCEDURE

BATTERY & CHARGING

If your machine is fitted with the fully automatic charger, please read on. If your machine is fitted with a different type, see documentation which should have been included with the unit.

The Charger has the following advantages:

- Waterproof
- Capable of charging batteries when motor is running.
- Dual voltage with auto select and indicator light to show voltage selected.
- Short circuit protection
- Designed to withstand heavy vibration
- Auto-boost to enable batteries to be kept in optimum condition when machine is in storage with charger connected.



The Charger (Black Box) shown here with 110V plug. To operate on 240V just replace plug

OPERATION

When connected to the mains supply the output current will be shown in the display window. With a 2/3 discharged battery the current will be in the region of 25A / 30A.

(Bulk Phase Light On)

When the battery voltage has reached gassing level (2.45V per cell) the timing phase will start (Gas Phase Light On). This timing period is calculated as follows: 1/2 the time it took to reach gassing level + 1 hour.

After the timing phase is completed the charger will switch itself into stand-by mode (Charge Complete Light On)

Take care to properly secure the wires. Burnt terminals indicate loose wires

FUSES :
24V = 15A

Type Bussman Ceramic MDA - (7 or 15)
250Volt, time Delay 1.25" x 0.25"

ERROR CODES

If the display panel on the black box is flickering between -1 and 2 you have a fault in the transformer or the black box.

Check the two output fuses under the terminal cover. The black box or the transformer contains no user replaceable parts. Opening the black box apart from the terminal cover shown will invalidate the warranty. If the Time Out Light comes on you have possibly a faulty battery. Check each cell with a hydrometer. The Time Out light will come on and the charger will switch off if gassing level has not been reached in 24hours.

Reverse Polarity Light will light if the output cables to the battery are reversed. Red Cable Must go to + battery terminal, Black Cable must go to - battery terminal.

CHARGING TIMES

The charger will recharge 2/3 discharged batteries in 8 to 10 hours. In reality batteries are often discharged more than 2/3 when used on a access platform. The operator tend to use the machine until the motor stops (This causes arcing of the motor contactor, and severe heat rise in the motor. Both of which shortens the components life considerably.) Then he forgets to put the machine back on charge until after the weekend. The result is that the battery can be as much as 95% discharge before the charger is connected (this causes severe reduction in battery life). If the battery cell voltage is below 1 volt the charger may not start. In that case, hold down the low voltage start button for several seconds. This will bypass the charger safety system and cause it to start irrespective of battery voltage. After the voltage has increased sufficiently for the controller to take over, you can let go of the button.

If gassing level is not reached in 24hours the charger will switch off and the Time Out Light will come on. Disconnecting the input lead will automatically re-set the timer. Take care not to disconnect the charger during a charging cycle. Always let the charger reach "Charge Complete" or "Time Out" to prevent overcharging.

PRACTICAL APPLICATIONS

The operator will run the batteries all the way down. Then he will try to connect the charger and continue working the machine. This will not work. The electric motor requires as much as 3 times the charger output. The charger will float on max 30A and the motor will not turn (This results in damage to the motor and contactor)

If the user has a very hectic work schedule he may run out of battery power before he has finished his work. In that case he can connect the charger to a mains supply before the batteries are 50% discharged. This will then give enough time for the charger to keep topping up the batteries and extend the duty cycle of the machine considerably.

The battery life may be slightly reduced as the optimum charging cycle for any battery is "fully charged - 2/3 discharged and then fully charged"

MAINTENANCE PROCEDURE

MAINTENANCE

- Check that the fuses are secured in the fuse holder.
- Check that all wires are secure on the terminal block and on the battery terminal.
- Check that the multi-pin plug is secure on the pcb.
- Check for damage to cables and wiring.

BATTERY

When charging the battery will give off explosive hydrogen gas. Keep away from open flames. Always wear appropriate personal safety equipments such as eye protection and rubber gloves to prevent injury in case of spillage.

Keep the top of the batteries clean and free from dirt. It is very easy for the battery to be contaminated when topping up with distilled water. The batteries are working very hard and regular topping up with distilled water will be required.

PRACTICAL APPLICATIONS

The most common problem is the operator complaining that

“The machine has just gone out on hire and did only 2 lifts - and yes we did have it on charge all last night before it went out”

You need to establish:

- Was the charger working ?
- Are the batteries in good condition ?

The most useful tool you can have is the Hydrometer ,to check the specific gravity, and a simple volt meter. Check each cell and see how they all compare. If one or more cell is significantly lower than the rest, replace all batteries. It is false economy to replace individual batteries.

To check if the charger works you can connect your voltmeter to the same battery terminals as the charger. Take a note of the reading. Now connect the charger to mains voltage.

You should see a marked increase in voltage. Also check the display on the charger. You can also connect an inline ammeter (or use a clamp on type) to check that the charger output display matches the current going into the batteries

BATTERY CHARGING USING GENERATOR

The charger can only be connected to a generator fitted with a full AVR (Automatic Voltage Regulator) and spike filtering system.

Large voltage fluctuations and spikes will damage the electronic components in the charger

We have found that the Honda Generator sets offer the best and most reliable voltage supply. This applies only to the fully integrated Honda generator sets and not the cheaper verity using a Honda Engine fitted with a non Honda generator unit.

ELECTRICAL SYSTEM

The electrical system is quite simple and requires minimal maintenance. The biggest problem is loose connections, again caused by vibration during towing, and the second is moisture or condensation caused by high humidity and temperature fluctuations.

Erratic running of the motor when depressing the green run button and moving the booms can be caused by an intermittent internal cable failure. The failure can be hard to locate. The best way is to lower the relevant boom. If the motor has stopped permanently, use the emergency lower system. Try to raise the boom again and see if the fault occurs roughly in the same place. If it does, it is highly likely you have an internal cable failure and the complete cable should be replaced.

On mains powered machine the control circuit is almost identical apart from voltage variants and the use of a isolation transformer on the control circuit. The bolt on motor contactor used on the DC pack is replaced by a combined thermal overload and motor contactor mounted inside its own junction box. On I.C. machines the boom circuit is the same as for the DC powered machines apart from the electrical start stop circuit needed for the engine.



EMERGENCY STOP

Two emergency Stops are fitted. One at each control post. When depressed they must stop all movements within a few seconds maximum. When activated it must not be possible to operate the machine. To release, turn 1/4 turn and the Emergency stop head will pop back out.

The switch head is not physically attached to the switch mechanism behind the head. If the head is released and the machine will not start check that the switch has not seized in the open position.

MAINTENANCE PROCEDURE

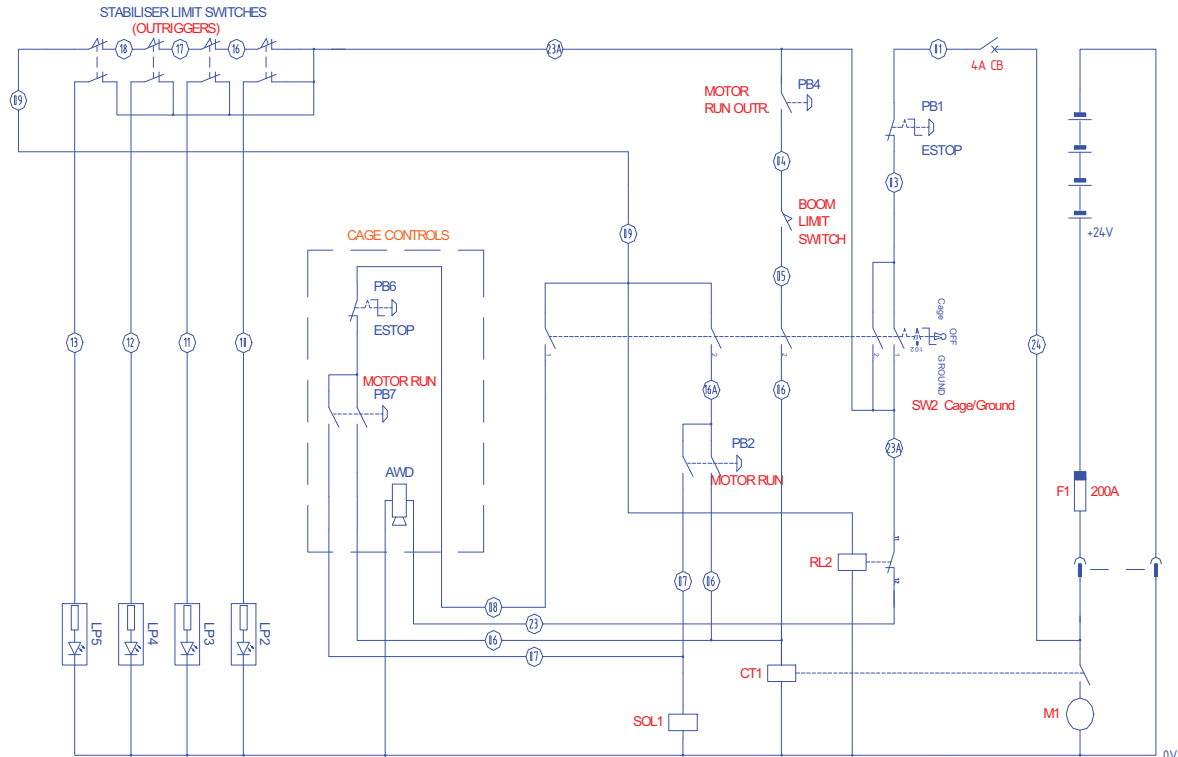

CT1 is mounted on top of the DC motor and switches the motor on/off

CB is a 4A Re-settable circuit breaker to protect the wiring loom from damage in case of a short circuit.

PB1 is the first emergency stop. Mounted on the ground controls.

SW2 is the key switch for selecting Cage or Ground controls and operating the outriggers. Turn to cage and switch set 1 closes. Turn to ground and switch set 2 closes

RL2 remains closed until the outriggers are under pressure.

AWD is the audible alarm fitted in the cage control box. The alarm is controlled by RL2.

PB4 is the black motor run switch on the ground control only used to start the motor when operating the outriggers.

Boom Limit Switch must be closed and the booms down to enable the motor to start and operate the outriggers.

Outrigger limit switch contain 2 N.C. contactor. One set controls the 4 LED's LP2-LP5. The other set is wired in series. When all the switches are closed, RL2 is activated. AWD stops

PB2 is the green motor run button on the ground controls. This switch becomes active after the SW2 is turned to ground and the 4 outrigger limit switches are closed.

SOL1 is the coil on the hydraulic diverter valve. When activated it prevents oil going to the outrigger control valve. It must be activated for the boom functions to work.

PB6 is the emergency stop button in the cage.

PB7 is the Green motor run button in the cage. After the key switch is turned to cage and the 4 outriggers are under pressure (PB6 not activated) pressing PB7 starts the motor. SOL1 is pulled in and the oil will flow to the cage control valve.

All wires are numbered as shown. Each wire terminal has the same number as the cable attached to it.

You will not be able to raise the outriggers unless the boom limit switches are activated as it is only PB4 which starts the electric motor without activating SOL1.

F1 protects the power side to the electric motor.

The battery can be isolated by pulling the Anderson plug next to the power pack

MAINTENANCE PROCEDURE

- The outriggers should be inoperable when the booms raise. If they can be operated, check the boom limit switch and the diverter valve. If the outriggers are inoperable with the booms lowered, check the boom limit switch and the diverter valve

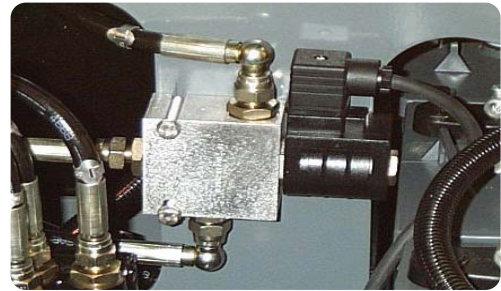
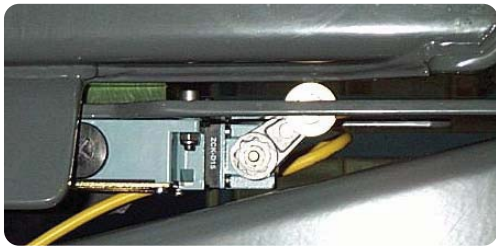

- If the emergency lowering valve on the top or bottom ram has been operated, fully extend the cylinder to fill the ram up with oil. Delay for several seconds the first time the cylinder is powered down, to allow it to fill with oil.

- To operate the emergency slew handle, the slew valve handle must be operated at the same time, allowing the oil to circulate.



- Check that the audible alarm is working. It should activate when a light leg is on.

- The booms are inoperable unless the outriggers are all down and in full contact with the ground. If the booms are operable, adjust the outrigger limit switch immediately. If the outrigger are set incorrectly the platform could become **unstable**. A light leg activating during use, will stop the machine and an audible alarm will sound. This is mounted on the underside of the cage control box. The hand pump must be operated to lower the platform and the outriggers re-set. Check that the LED on the ground control panel is working correctly. Each LED should only come on when the associated outrigger is in contact with the ground



WHEELS

Check for damage to the tyre. Replace if tread pattern is worn below 3mm. On machines with sliding axle you will see increased wear on the inside part of the tyre compared to the outside part. It is important that correct tyre pressure is maintained at all times. The correct pressure is 5.2bar (76PSI) and not what may be indicated on the tyre. See separate tyre pressure decal fitted to the top of the mudguard. Tyre size is : 215/75 R16 8ply.

IMPORTANT

For fully service and maintenance information on the running gear contact Snorkel and request a copy of the running gear OEM service handbook. Below are a few important extracts which covers the some of the basic checks to carry out when servicing the machine. If the handbrake is not fully applied there is a risk that the trailer could run backwards. The brake rod must not be under tension or bowed when the handbrake is disengaged.

BRAKES

Check Bowden cable for damage - Replace if inner steel core is visible. Sticking brakes can be down to seized cables. The inner steel wire must run freely inside the cable.

Adjust the brakes with the wheels removed. Remove the plastic bung in the back of the brake plate. Use a screw driver to adjust the star wheel until resistance is felt when turning the brake drum in the direction of travel. Then slack back until the brake drum turns freely.

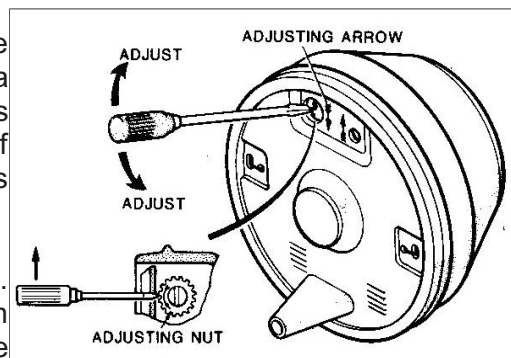

Check for correct movement of the Bowden cable. The cable should move 5 to 8 mm. Check for uniform response when braking. All adjustment must be done at the wheel brake and not on the brake linkage.

When removing the drum for cleaning the brake shoes. Always ensure that a new flanged nut is used. Tighten the flange nut to 280Nm - 300Nm. When refitting the wheel, tighten wheel nuts in the N.S.W.E sequence and to a torque of 88Nm.

AXLE

The axle is fully maintenance free. Check fixing bolts. If ordering replacement axle quote all ref. numbers on the oval serial number plate riveted to the axle beam.

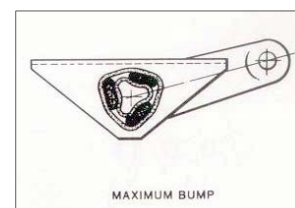
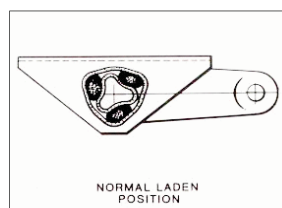
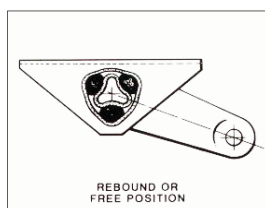

MAINTENANCE PROCEDURE

COUPLING / OVERUN DEVICE

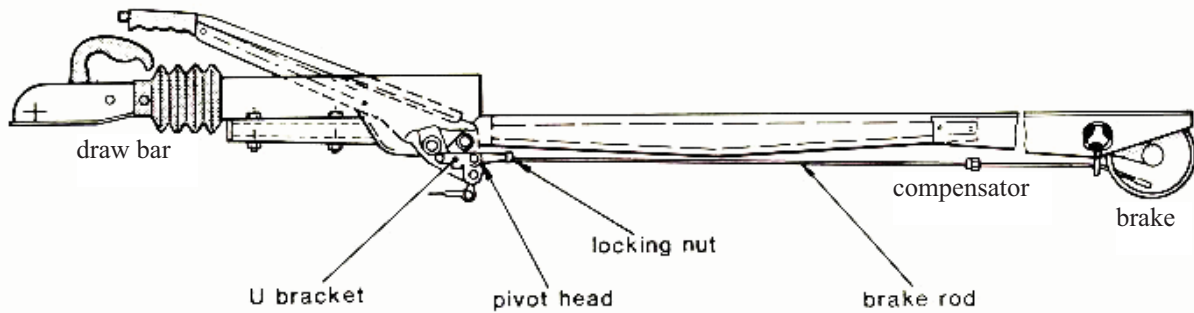

Ensure that the draw bar is fully extended. Screw the brake rod into the pivot head and secure with a M10 nut. Using the M10 ball nut, connect the brake rod to the Bowden cable via the compensating bracket. Fit and hand tighten the hex securing nut. Tighten the M10 ball nut on the brake rod until there is no further play on the pivot head against the draw bar (the draw bar must be fully extended).

The compensating bracket must be square on the brake rod. The current type of Bowden cables are non adjustable. Hook the cable on to the compensator bracket. Adjust to ensure even braking on the brake, not on the compensator.

Check that both wheels run freely in the forward direction. Apply handbrake, the brakes should start to come on at the second click. The gas strut will ensure that the handbrake is fully applied. If the trailer is moving backwards the handbrake will move further up. This is normal. It is imperative that the gas strut is working correctly. Without the gas strut the brakes will not hold the trailer on a slope.

Adjust brakes if required.

Check that all nuts are secure.
Grease the coupling head.
Multipurpose grease to DIN 51825 KTA 3K

Clean and oil all other moving parts.

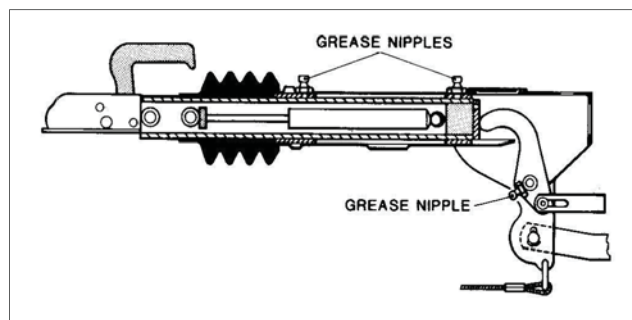

WHEEL BEARINGS

The wheel bearings are sealed for life and require no maintenance or grease. The service life for a set of bearings is in the region of 20,000 to 30,000 miles, depending on running conditions. It is vital that the brakes have not been overheated as this will cause the grease in the sealed ball bearings to evaporate and the bearings will fail.

Never re-use the flanged nut when refitting the brake drum as the wheel may come off when towing

When purchasing a brake drum the bearings are normally included, fitted to the brake drum. If replacing bearings only, contact Snorkel or its local representative for further information. Always use a new flanged nut and torque to 280—300Nm when refitting the drum.

13 PIN CONNECTOR

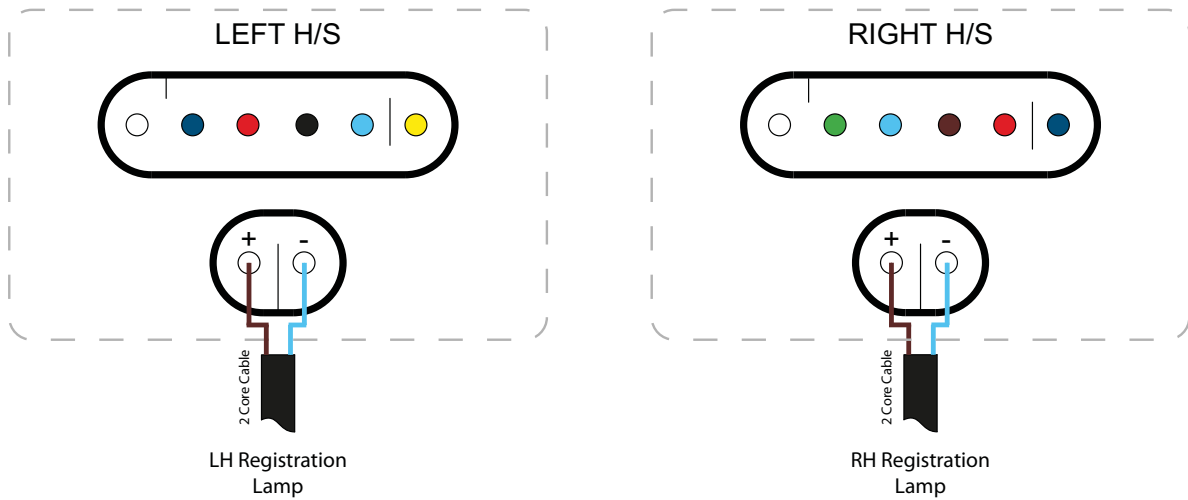
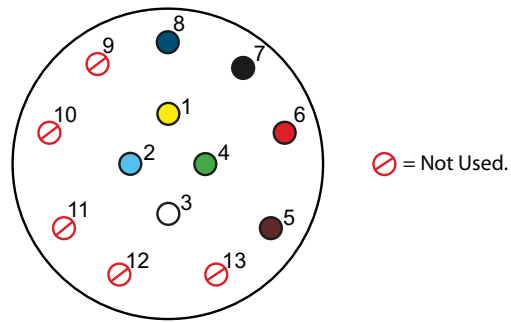

13 PIN CONNECTOR

PIN	FUNCTION	COLOUR
1	LH INDICATOR	YELLOW
2	FOG LAMP	BLUE
3	NEGITIVE	WHITE
4	RH INDICATOR	GREEN
5	RH TAIL LAMP	BROWN
6	BRAKE LAMP	RED
7	LH TAIL LAMP	BLACK
8	REVERSING LAMP	DARK BLUE
9	NOT USED	N/A
10	NOT USED	N/A
11	NOT USED	N/A
12	NOT USED	N/A
13	NOT USED	N/A

MAINTENANCE PROCEDURE

GENERAL GREASE POINTS

Regular greasing not only greatly improves the service life of the bushes, it also will remove any moisture which may cause internal corrosion on the wall of the bosses making it difficult to remove the pivot shafts for inspection.



LUBRICATION SPECIFICATIONS

We recommend only using premium quality grease. Experience has shown that a Lithium based grease offers very good performance. For the slew ring the RENOLIT ARMNA G4789 from Fuchs offers extremely good lubrication and anti corrosion properties. Especially at very low temperatures (-30DegC)

SLEW DRIVE

To grease the slew ring you must set the machine up and slew around so you can gain access to the reassessed grease nipple fitted to the top face of the slew ring.

When greasing the worm housing take care not to push out the oil seal on the end face. If you do, remove excess grease from the end and drive the seal back in.. See Slew Drive Gear section for more details.

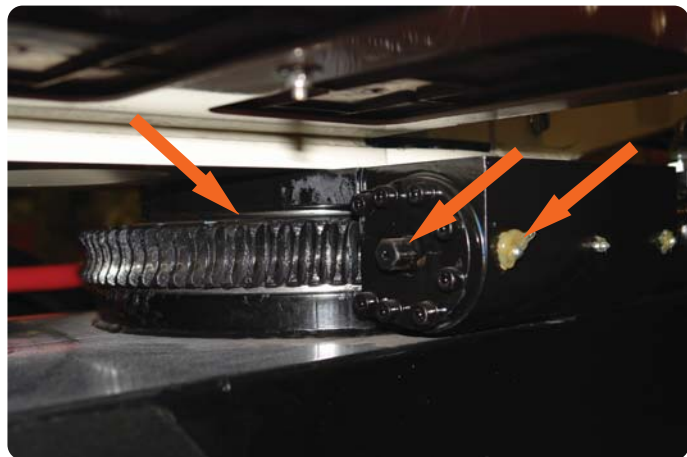

SLEW DRIVE GEARS

The slew drive gear is designed to be largely maintenance free. However, we recommend the gear teeth be greased on a weekly / monthly basis with a high pressure grease depending on operating conditions. Always clean the gear first to remove any road dirt and grime. In very dusty or sandy conditions take care to prevent a build-up of grit / sand mixed with grease which may cause premature wear on the gear.

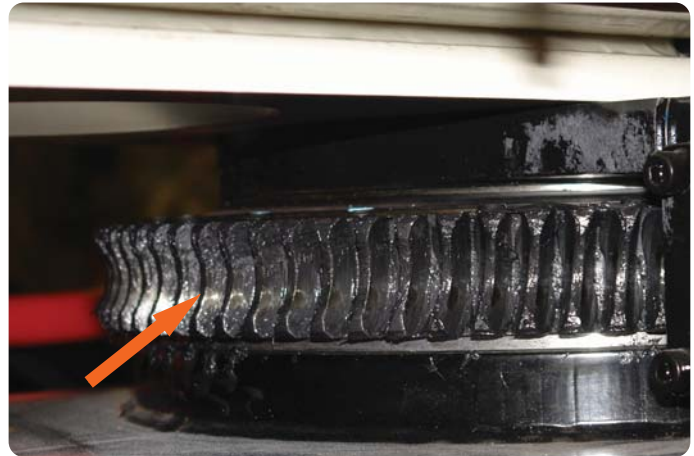

Additionally, the ring gear and gear box should be greased on a six monthly basis. The grease nipple for the ring gear is on the top face of the slew gear, set between the fixing bolts. It can be accessed by lifting one of the side covers, and slewing the structure appropriately.

The ring gear should be inspected on a six monthly basis for excessive play. It is unlikely there will be any wear if the machine is maintained correctly.

To check the gear, place a payload of approximately 80Kg in the platform. Elevate the lower boom to approximately half way. Then gently elevate the top boom, whilst observing the ring gear. Excessive wear will be observed by noticing more than 0.5mm movement between the inner and outer bearing rings. If excessive wear is present the gear ring should be replaced.

MAINTENANCE PROCEDURE

The slew stop mechanism is fully lubricated and should normally not require any further lubrication. Should more lubrication be needed this can be done in two ways.

- 1) When greasing the slew bearing some grease will drop in to the centre part of the slew. Keep on greasing the slew bearing until the grease escapes from the outside sealing lip on the slew gear. Continue greasing, as the grease will now be pushed out through the outer and inner sealing ring of the slew bearing.
- 2) Grease escaping from the inner seal will drop onto the slew stop ring.
- 3) Also spray LPS-3 lubrication up between the Slew tube and the chassis plate.

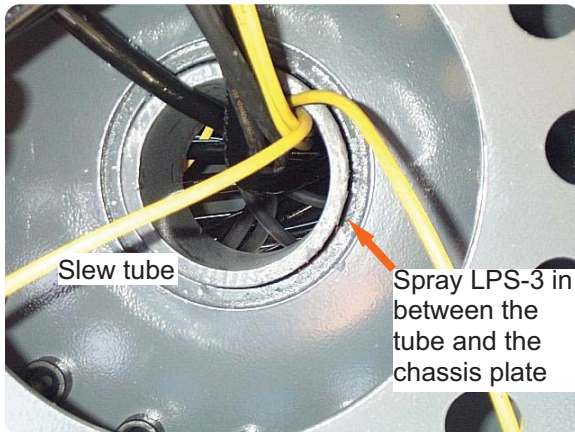

How does the slew stop work ?

The slew stop mechanism is very simple and prevent the cables and hoses getting tangled up by continuous rotation. The Slew stop ring will allow the operator to turn almost 360 deg in each direction from the stowed position.

The critical parts of the slew stop are as follows :

Chassis stop

Slew stop ring

Slew stop ring tab

Slew tube stop

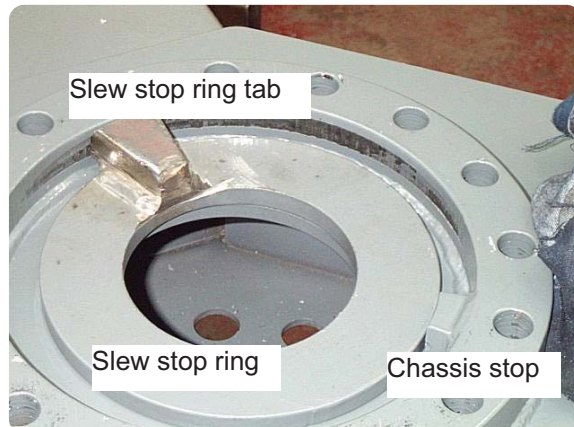

When slewing (rotating) the Slew tube stop will pick up on the Slew stop ring tab and drag it around until Slew stop ring tab hits the Chassis stop. The platform can now slew almost two turns in the opposite direction until the Slew stop ring tab hits the Chassis stop. This gives you almost two turns "lock to lock". From the parking position this equates to "one turn left or one turn right" measured from the parking position

What can go wrong ?

The mechanism is very simple and has proven reliable in the field. However If the slew does not stop, check that one of the 3 steel stop blocks has broken loose.

If this is not rectified the platform can slew continually and will rip out the hoses and cables. To solve this problem, split the machine and re-weld the slew stop.

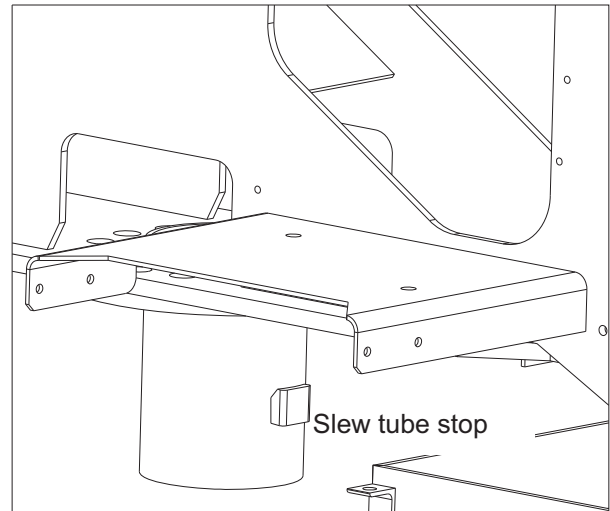

Check hydraulic pressure. Apply plenty of lubrication to ensure that the slew stop ring has not got jammed. Again if the problem does not disappear you have to split the machine to investigate further.

IMPORTANT

THOROUGH INSPECTION

All machines being operated in the UK must have a thorough inspection carried out every 6 months in accordance with LOLER Regulations 1998 and a Certificate of Thorough Inspection produced by a competent person.

When the machine has passed its test the machine will be issued with a sticker showing the Certificate number and the date of next Examination. A copy of the Certificate is available upon request.

Contact **Snorkel** for further details

CONTENTS

	Page Number
Illustrated Mechanical Parts List	2
Electrical Parts List	27
Hydraulic Hose and Fittings Lists	29
Electrical Schematics	
Battery Power	33
Mains Power	34
Diesel/Petrol	35
Bi-Fuel Power	36
Hydraulic Schematics	
Battery/Mains Power	37
Diesel/Petrol	38
Bi-Fuel Power	39
Friction Drive Option	40

LIGHTING BOARD ASSEMBLY

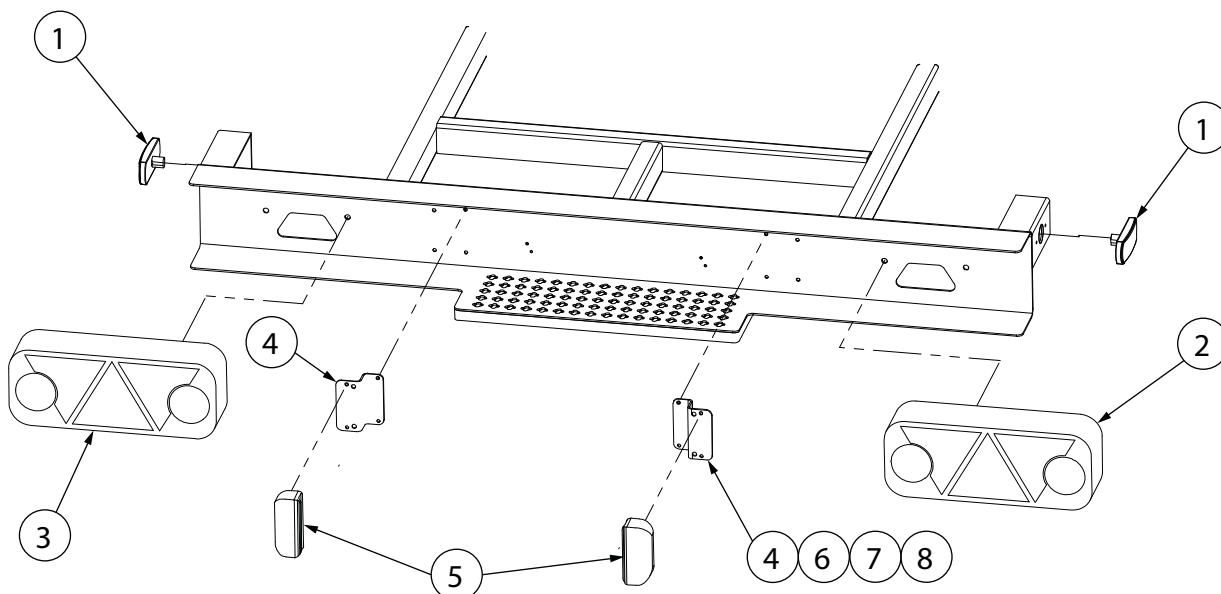

Lighting Board Assembly			
Item	Part No.	Description	Qty.
1	512492-000	AMBER REFLECTOR	2
2	513301-000	RH LIGHT CLUSTER	1
3	513302-000	LH LIGHT CLUSTER	1
4	513742-000	REGISTRATION LAMP MOUNTS	2
5	513300-000	REGISTRATION LAMP	2
6	058490-016	SET SCREW, M5 x 16mm	4
7	056069-005	M5 FLAT WASHER	8
8	056066-005	M5 NYLOCK NUT	8

Marker Lamp Kit (NOT SHOWN)		
Part No.	Description	Qty.
513836-000	Harness, Tow Hitch to Chassis	1
513836-001	Harness, Chassis to Side Marker Lamps	1
513839-000	Harness, Rear Light to Registration Lamp	2
513838-000	Harness, Rear Light to Side Marker Lamp	2
513492-000	Amber Marker Lamp	6
513403-000	White Reflector	2
512687-000	13 Pin Plug	1
512689-000	8 Core Cable	10m

OUTRIGGER COMPONENTS

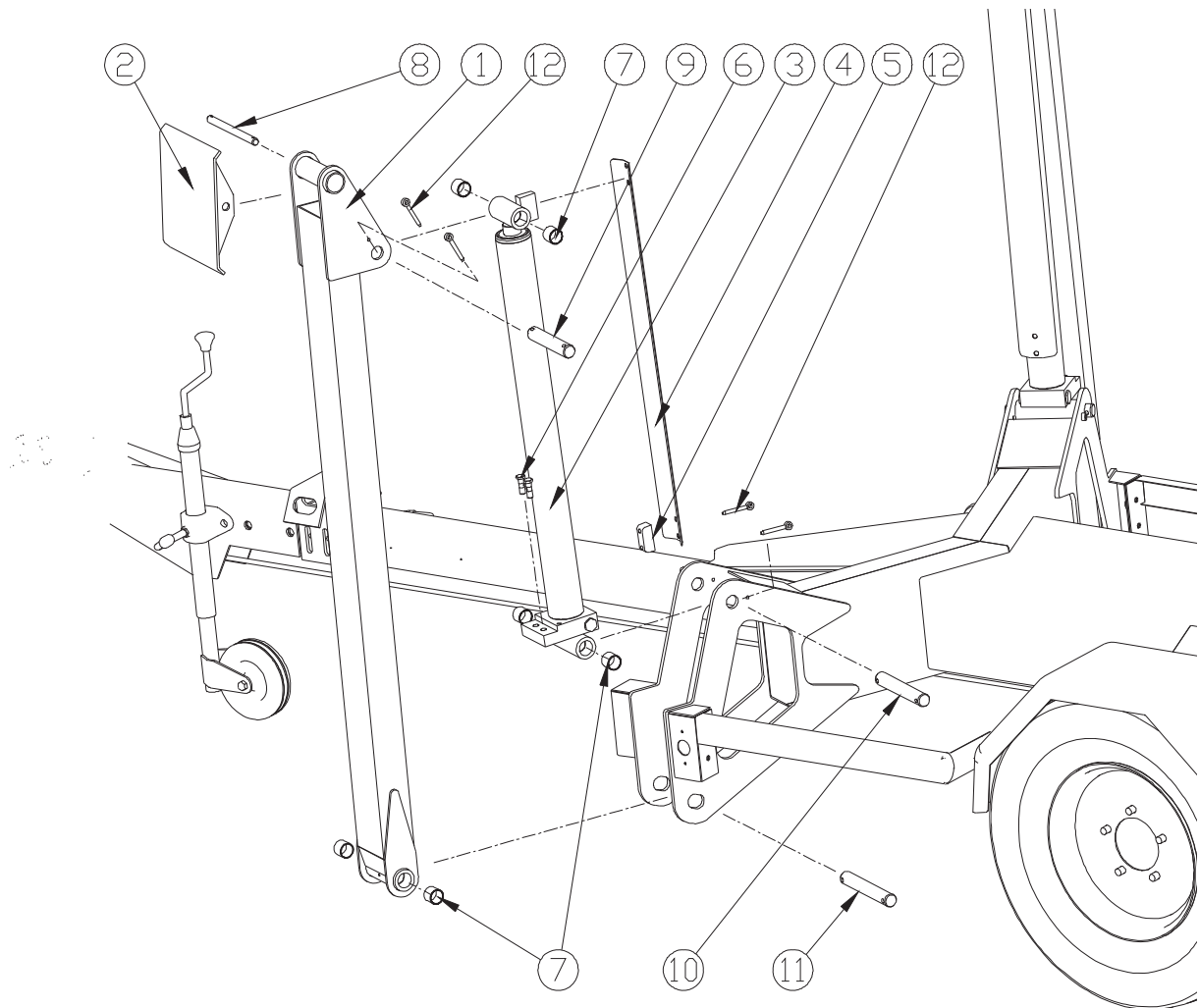

Outrigger Components			
Item	Part No.	Description	Qty.
1	10-5069	Outrigger	4
2	10-5070	Outrigger Foot	4
3	13-3608	Outrigger Ram	4
4	22-5179	Outrigger Ram Cover	4
5	15-0886	Ram Cover Skid Pad	4
6	12-2054	Banjo Bolt	8
7	SB-030030	Bush	24
8	SP-016E216	Pin	4
9	SP-030D171	Pin	4
10	SP-030D203	Pin	4
11	SP-030K211	Pin	4
12	10-2672	Retaining Peg	16

CHASSIS COMPONENTS

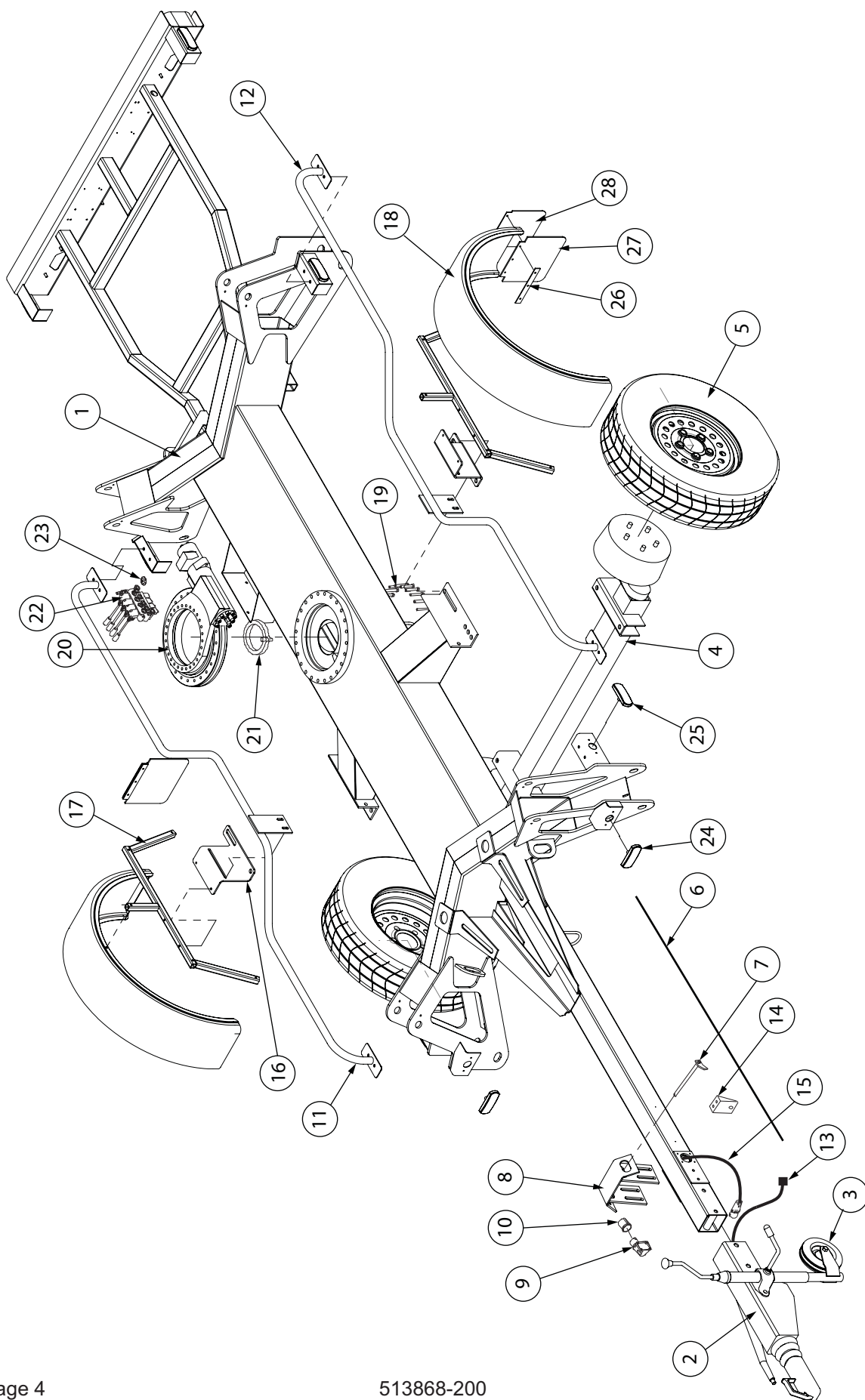

CHASSIS COMPONENTS

Chassis Components			
Item	Part No.	Description	Qty.
1	513439-000	Chassis	1
2	508106-000	Towing Coupling	1
3	508107-000	Adjustable Jockey Wheel	1
4	513441-000	3000Kg Rubber Suspension Axle c/w Brake Cables	1
5	513443-000	215/75R16 Wheel Assembly (5 Stud)	2
	03 0275/01	Wheel Studs	10
	03-0275/02	Wheel Nuts	10
6	24-3998	Brake Rod	1
7	21-0855	Boom Retaining Pin	1
8	10-5068	Boom Lock	1
9	09-1273	Inlet Plug	1
10	09-1394	Inlet Plug Cap	1
11	513398-000	Cycle guard R/H	1
12	513397-000	Cycle guard L/H	1
13	508133-000	Bowden Cable	1
14	508134-000	Cable Bracket	1
15	508112-000	NATO Plug	1
16	513450-000	Mudguard Support Bracket L/H	1
	513449-000	Mudguard Support Bracket R/H	1
17	513416-000	Mudguard Mount Bracket	2
	513793-000	Mudguard Mount Bracket (Friction Drive units only)	2
18	IT250	Mudguard	2
19	11-3449	Bolt (M12 x 80mm)	26
20	08-0192	Slew Bearing/worm Drive c/w Motor	1
21	10-5271	Slew Limiting Ring	1
22	13-2537	Stabiliser Control Valve	1
23	25-0239	Levelling Bubble	1
24	513403-000	White Marker Lamp	2
25	513492-000	Amber Marker Lamp	6
26	513522-002	Mudflap Bracket	
27	513522-000	Mudflap	
28	513522-001	Mudflap Support Bracket	
Brake Hub Components			
Part No.	Description	Qty.	
14305.08	Knott 300 x 60 Std. Brake Assembly	2	
DPSM 63 90 10	Oil Seal	2	
368A / 362A	Inner Bearing Cone/Cup	2	
LM501349 / 501310	Outer Bearing Cone/Cup	2	
24929.03	Standard Brake Shoe	2	
1053 08	Load Washer	2	

SLEW COMPONENTS (BI-FUEL POWER)

Slew Components (Bi-Fuel Powered Machine)			
Item	Part No.	Description	Qty.
1	10-5071	Slew Platform	1
2	16-0147	GRP Cover	1
3	16-0148	GRP Cover	1
4	15-0858	Hinge	4
5	24-4097	Cover Stay	2
6	10-5266	Power-pack Tray	1
7	10-5267	Battery Tray	1
8	22-5576	Cross Brace	1
9	09-1185	Battery 6v	4
10	TA0064-2639	Battery Power Connectors	2
11	09-2280	Platform Charger/Transformer Module	1
12	19-0154/2	Hand-pump Handle	1
13	19-0154/1	Hand-pump	1
14	19-0154	Power-pack	1
15	09-0998	Contactor	1
16	13-3609	Hydraulics Manifold	1
17	02-2639	Electrical Control Box (Parts list	1
18	22-5581	Control Box Cover	1
19	13-0888	Base Control Valve	1
20	11-3448	Bolt (M12 x 85mm)	28
21	10-2672	Retaining Peg	2
22	24-2880	Retaining Peg - Large	2
23	SP-035D320	Pin	1
24	21-0852	Pin	2
25	2-5577	Splash Guard	1
26	20-0055	Kubota OC60 diesel engine c/w stop/start kit	1
27	13-0529	In-Line Check Valve	2
28	13-1949	Bell Housing	1
29	13-1950	Flexible Coupling	1
30	13-3649	Pump	1
31	13-3650	Outlet Elbow	1
32	13-3651	Suction Elbow	1
33	10-5269	Engine Mounting Bracket	1
34	10-5270	Battery/Pump Cover	1
35	09-1009	Battery 12v	1
36	11-3438	Clamp Plate	2
37	22-5177	Battery Clamp Rod	2
38	09-1393	230vPlug	1
39	13-0146	3-way Valve	1
40		Engine Jump-start Battery Kit	1
	G70241	Battery Disconnect Connector, Female	1
	G70242	Battery Disconnect Connector, Male	1
	G70243	Battery Disconnect Connector, Handle	1
41	508136-000	Hydraulic Tank Drain Kit	1

SLEW COMPONENTS (BI-FUEL POWER)

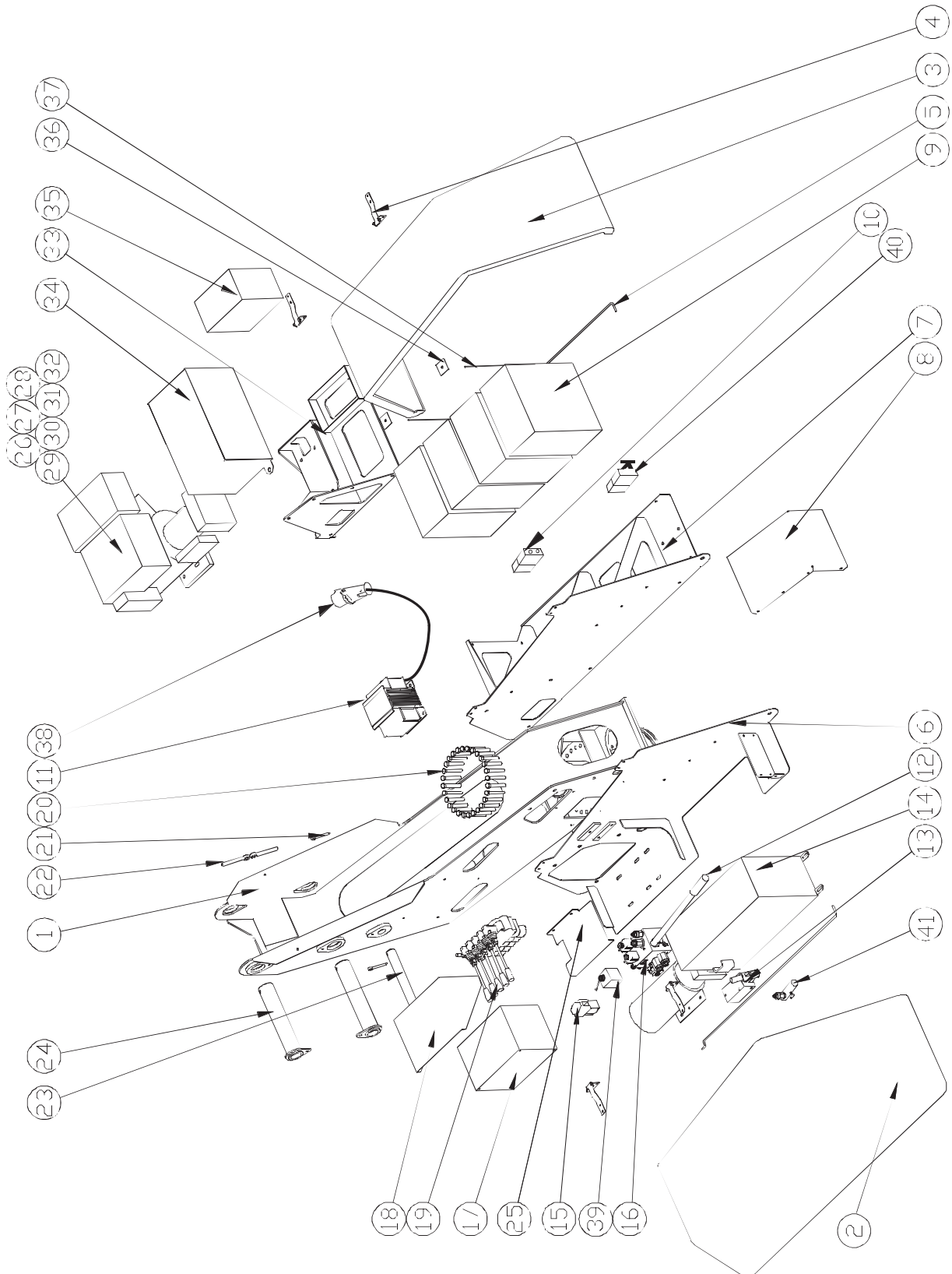

SLEW COMPONENTS (MAINS POWER)

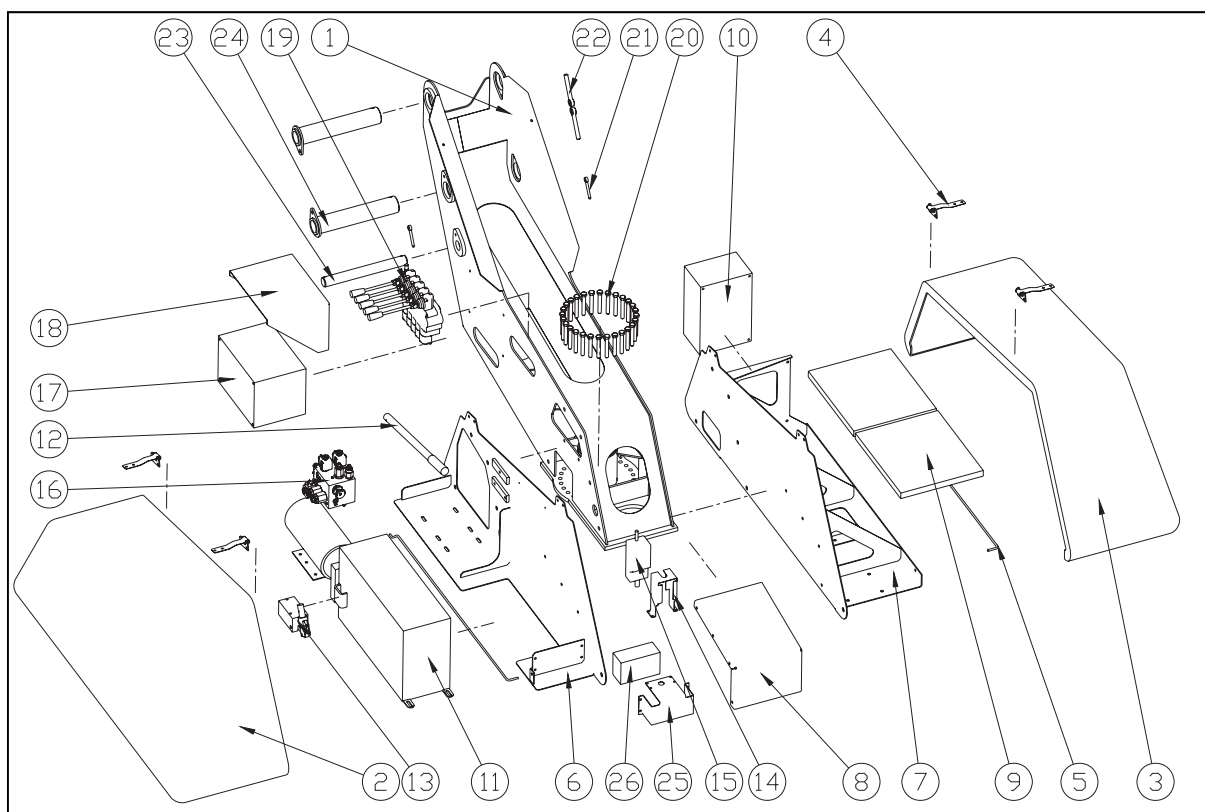

Slew Components (Mains Powered Machine)			
Item	Part No.	Description	Qty.
1	10-5071	Slew Platform	1
2	16-0147	GRP Cover	1
3	16-0148	GRP Cover	1
4	15-0858	Hinge	4
5	24-4097	Cover Stay	2
6	10-5266	Powerpack Tray	1
7	10-5267	Battery Tray	1
8	22-5576	Cross Brace	1
9	-	Ballast Plate	2
10	-	230V Control Box	1
11	19-0155	Powerpack	1
12	19-0154/2	Handpump Handle	1
13	19-0154/1	Handpump	1
14	22-5516	Float Charger Cover	1
15	09-1937	Float Charger	1
16	13-3609	Hydraulics Manifold	1
17	-	Slew Control Box	1
18	22-5581	Control Box Cover	1
19	13-0888	Base Control Valve	1
20	11-3448	Bolt	28
21	10-2672	Retaining Peg	2
22	24-2880	Retaining Peg - Large	2
23	SP-035D320	Pin	1
24	21-0852	Pin	2
25	22-5508	Emergency Battery Holder	1
26	09-2087	Dry Battery	1

SLEW COMPONENTS (BATTERY POWER)

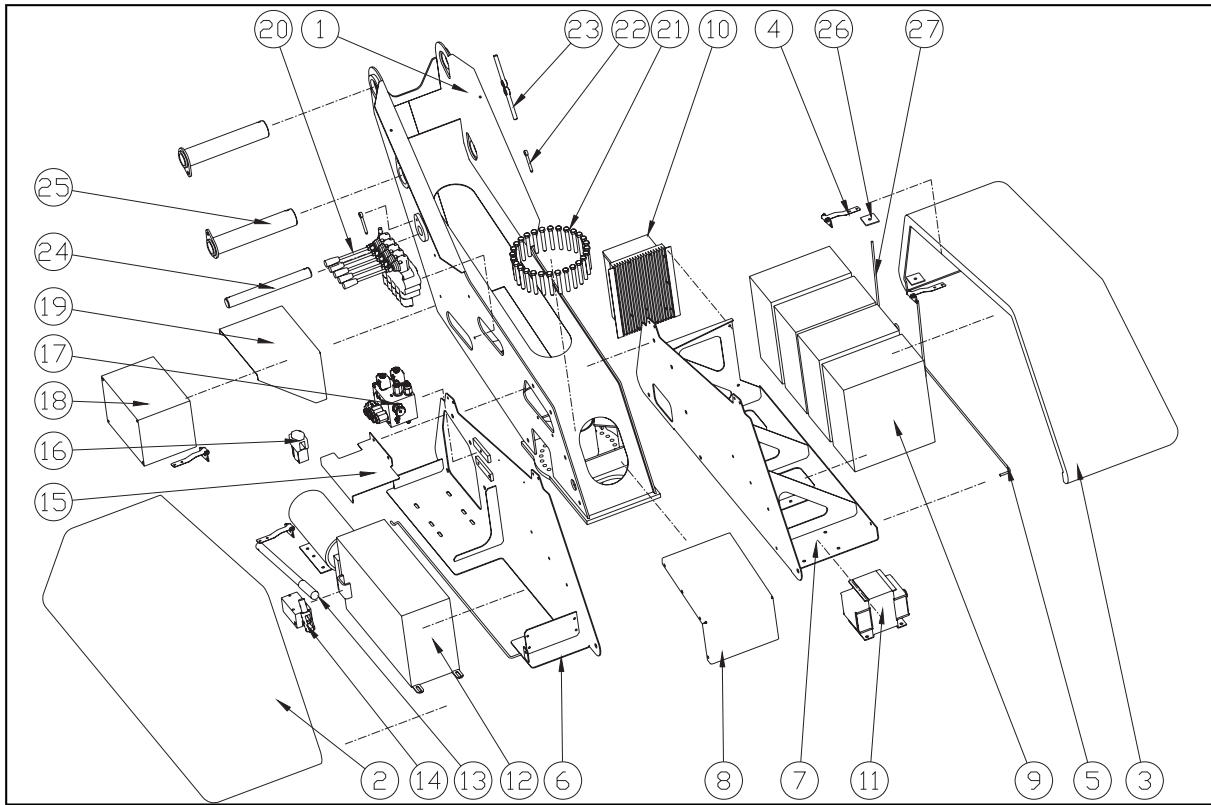

Slew Components (Battery Powered Machine)

Item	Part No.	Description	Qty.
1	10-5071	Slew Platform	1
2	16-0147	GRP Cover	1
3	16-0148	GRP Cover	1
4	15-0858	Hinge	4
5	24-4097	Cover Stay	2
6	10-5266	Powerpack Tray	1
7	10-5267	Battery Tray	1
8	22-5576	Cross Brace	1
9	09-1185	Battery	4
10	09-1663	Charger Power Module	1
11	09-1665	Transformer	1
12	19-0154	Powerpack	1
13	19-0154/2	Handpump Handle	1
14	19-0154/1	Handpump	1
15	22-5577	Splash Guard	1
16	09-0998	Contactor	1
17	13-3609	Hydraulics Manifold	1
18	-	Slew Control Box	1
19	22-5581	Control Box Cover	1
20	13-0888	Base Control Valve	1
21	11-3448	Bolt	28
22	10-2672	Retaining Peg	2
23	24-2880	Retaining Peg - Large	2
24	SP-035D320	Pin	1
25	21-0852	Pin	2
26	11-3438	Clamp Plate	2
27	22-5177	Battery Clamp Rod	2

SLEW COMPONENTS (ENGINE POWER)

Slew Components (Engine Powered Machine)			
Item	Part No.	Description	Qty.
1	10-5071	Slew Platform	1
2	16-0147	GRP Cover	1
3	16-0148	GRP Cover	1
4	15-0858	Hinge	4
5	24-4097	Cover Stay	2
6	10-5266	Powerpack Tray	1
7	10-5267	Battery Tray	1
8	22-5576	Cross Brace	1
9	-	Ballast Plate	2
10	HS03	Sight Gauge	1
11	10-5310	Hydraulic Tank	1
12	19-0154/2	Handpump Handle	1
13	19-0154/1	Handpump	1
14	13-0339	Suction Strainer	1
15	13-2543	Return Line Filter	1
16	13-3609	Hydraulics Manifold	1
17	-	Slew Control Box	1
18	22-5581	Control Box Cover	1
19	13-0888	Base Control Valve	1
20	11-3448	Bolt	28
21	10-2672	Retaining Peg	2
22	24-2880	Retaining Peg - Large	2
23	SP-035D320	Pin	1
24	21-0852	Pin	2
25	22-5613	Tank Lid	1
26	20-0044	Engine (Petrol)	1
26	20-0055	Engine (Diesel)	1
27	13-0529	In-Line Check Valve	2
28	13-1949	Bell Housing	1
29	13-1950	Flexible Coupling	1
30	13-3649	Pump	1
31	13-3650	Outlet Elbow	1
32	13-3651	Suction Elbow	1
33	10-5269	Engine Mounting Bracket	1
34	10-5270	Battery/Pump Cover	1
35	09-1009	Battery	1

SLEW COMPONENTS (ENGINE POWER)

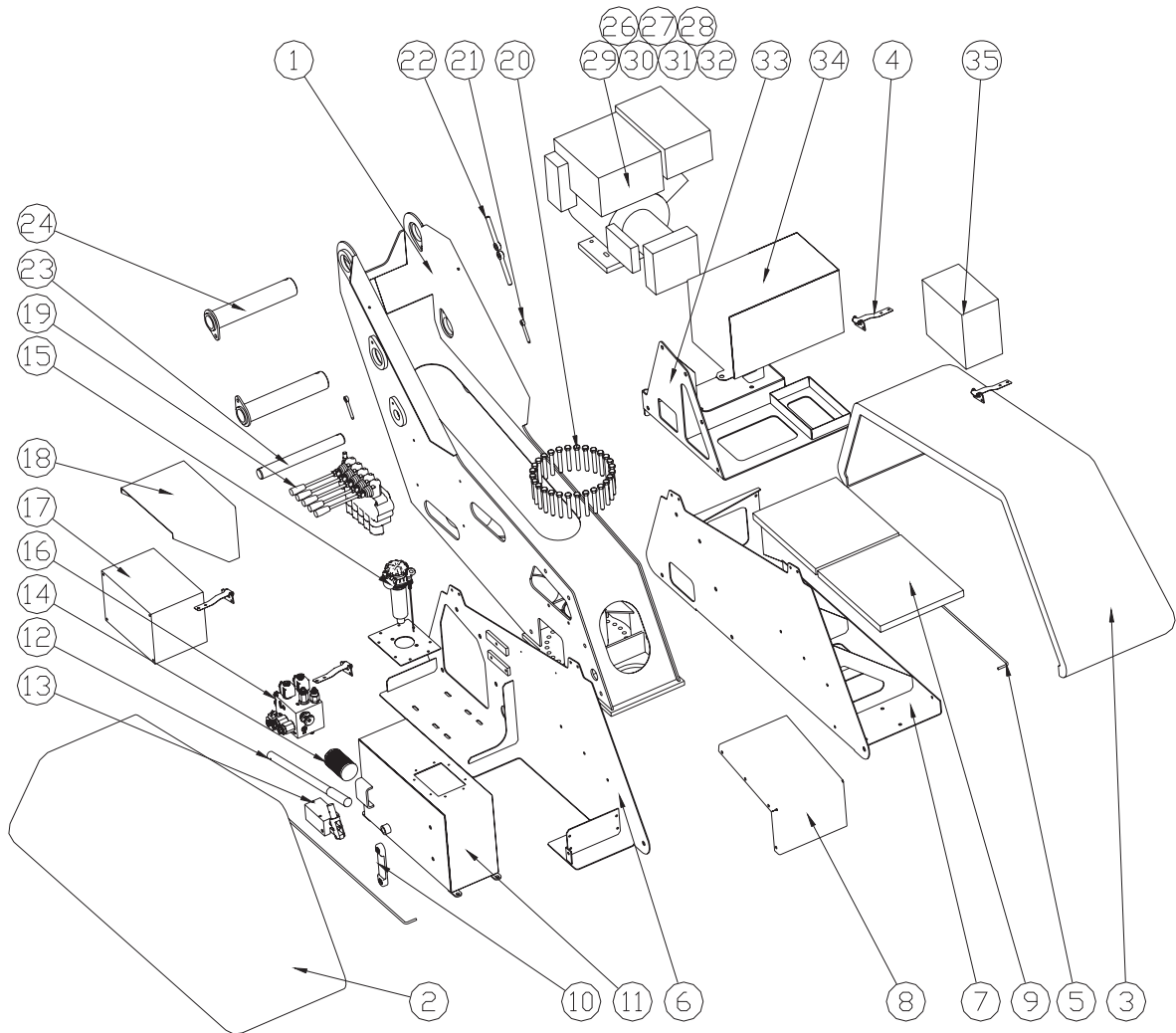

LOWER BOOM COMPONENTS

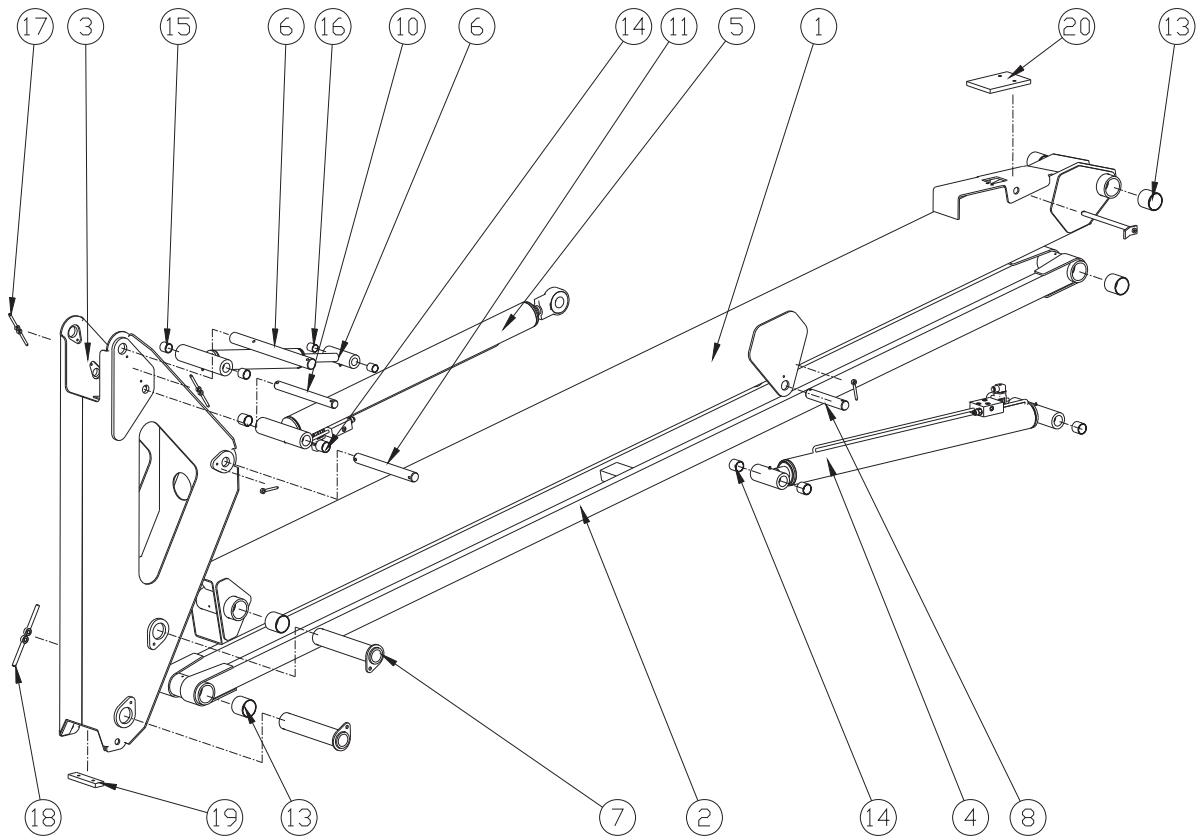

Lower Boom Components			
Item	Part No.	Description	Qty.
1	10-5072	Bottom Boom	1
2	10-5073	Tie Bar	1
3	10-5263	Vertical Boom	1
4	13-3607	Bottom Ram	1
5	13-3606	Top Ram	1
6	13-3604	Master Ram	1
7	21-0852	Pin	2
8	SP-035D201	Pin	1
9	21-0850	Pin	1
10	SP-030D320	Pin	1
11	SP-035D320	Pin	1
12			
13	SB-060060	Bush	8
14	SB-035035	Bush	6
15	SB-030030	Bush	2
16	SB-025025	Bush	2
17	10-2672	Retaining Peg	8
18	24-2880	Retaining Peg	2
19	15-0884	Boom Rest Pad	1
20	15-0883	Boom Rest Pad	1

TOP BOOM COMPONENTS

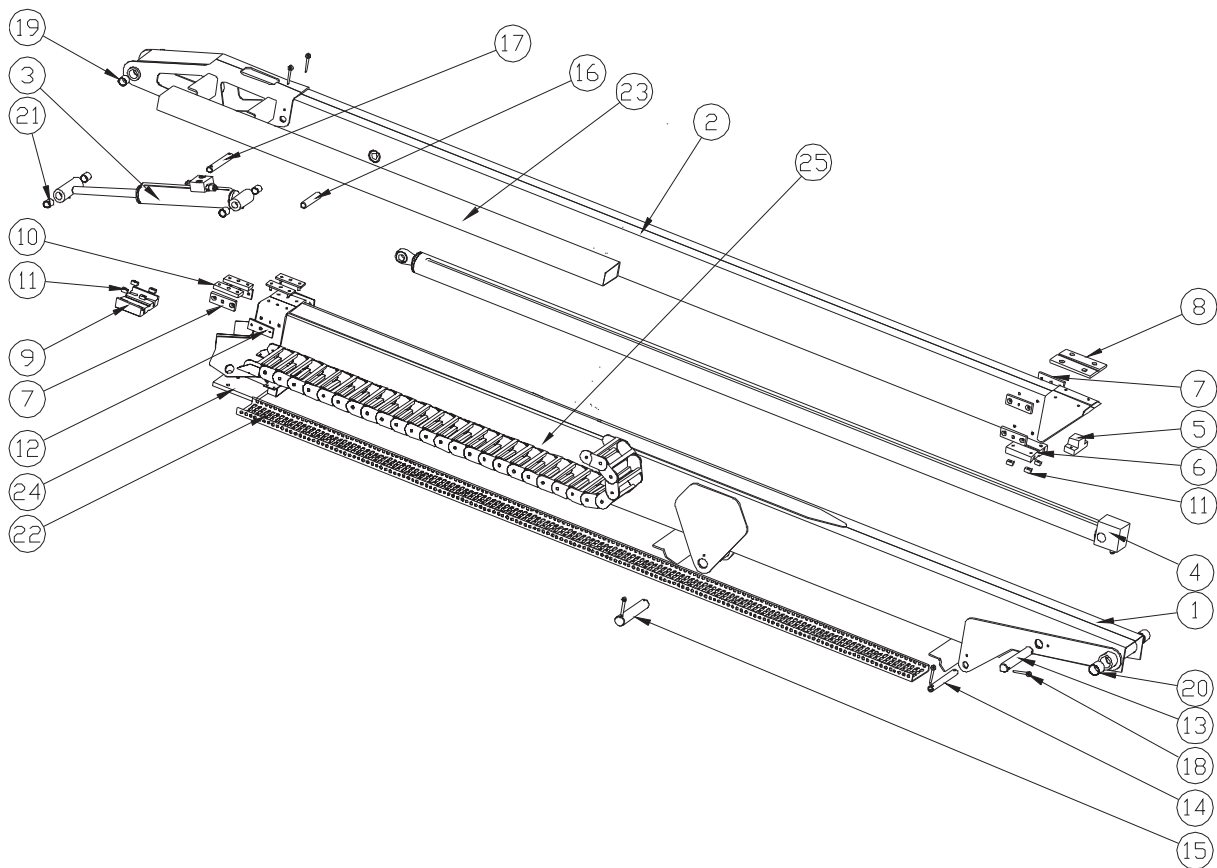

Top Boom Components			
Item	Part No.	Description	Qty.
1	10-5075	Top Boom	1
2	10-5076	Telescopic Boom	1
3	13-3603	Cage Levelling Ram	1
4	13-3605	Telescope Ram	1
5	15-0899	Tele Ram Support Block	1
6	15-0881	Wear Pad	1
7	15-0880	Wear Pad	6
8	15-0895	Wear Pad	1
9	15-0896	Wear Pad	1
10	15-0882	Wear Pad	2
11	24-3952	Pad Retaining Nut	8
12	10-5138	Wear Pad Keep Plate	4
13	SP-035D203	Pin	1
14	SP-025D200	Pin	1
15	SP-040D203	Pin	1
16	SP-025A120	Pin	1
17	SP-025D164	Pin	1
18	10-2672	Retaining Peg	8
19	SB-030030	Bush	2
20	SB-040040	Bush	2
21	SB-025025	Bush	4
22	09-2121	Cable Tray	1
23	24-3909	Hose Trunking	1
24	15-0883	Boom Rest Pad	1
25	15-1009	Drag-chain Complete	1

DROPNOSE COMPONENTS

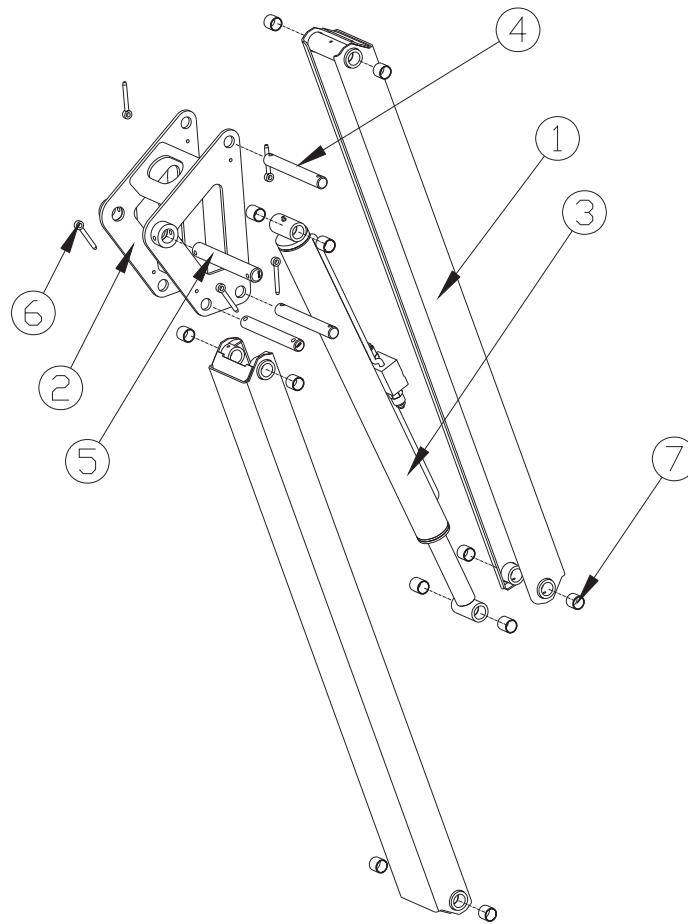

Drop-nose Components			
Item	Part No.	Description	Qty.
1	10-5078	Drop-nose Boom	2
2	10-5077	Quadrant	1
3	13-3602	Drop-nose Ram	1
4	SP-025D200	Pin	3
5	SP-030D216	Pin	1
6	10-2672	Retaining Peg	6
7	SB-025025	Bush	12

CAGE SUPPORT COMPONENTS

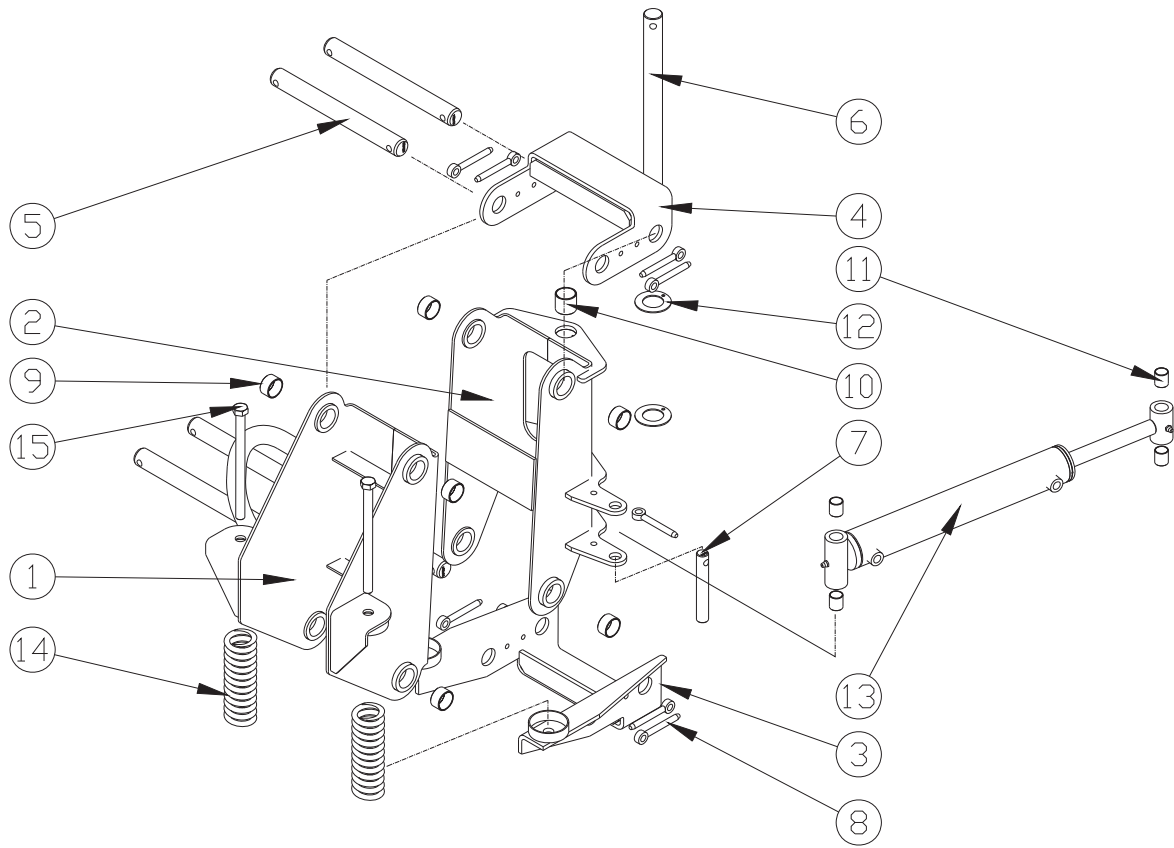

Cage Support Components			
Item	Part No.	Description	Qty.
1	10-5232	Pivot Support	1
2	10-5231	Cage Slew Pivot	1
3	10-5229	See-Saw Bracket	1
4	10-5230	Upper Link Bracket	1
5	SP-025D235	Pin	4
6	SP-025D330	Pin	1
7	SP-016B108	Pin	1
8	10-2672	Retaining Peg	9
9	SB-025015	Bush	8
10	SB-025025	Bush	2
11	SB-016020	Bush	4
12	04-0113	Thrust Washer	2
13	13-2403	Cage Rotation Ram	1
14	23-0031	Spring	2
15	11-3442	Bolt (M12 x 170mm)	2

STEEL CAGE COMPONENTS

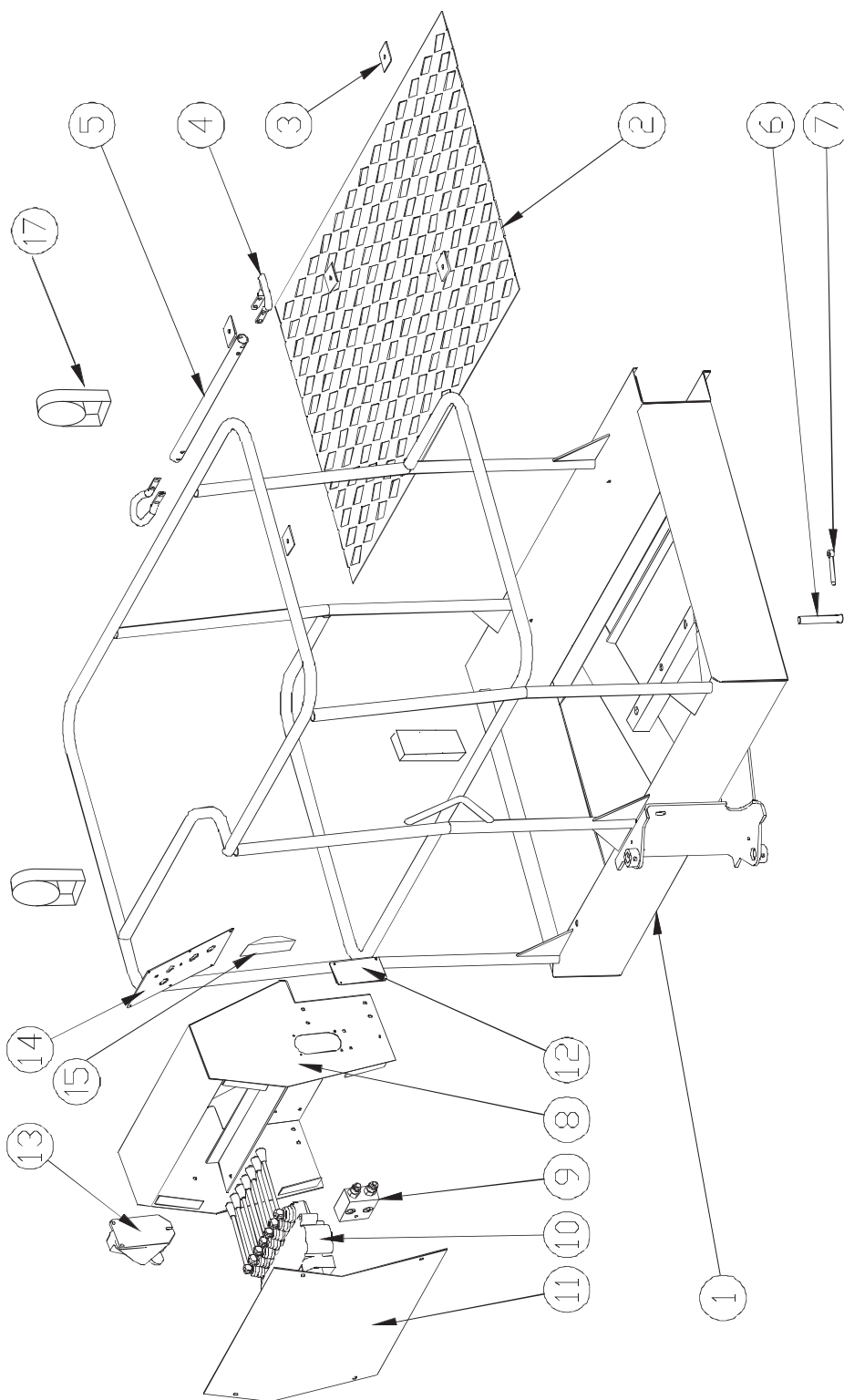

STEEL CAGE COMPONENTS

Steel Cage Components			
Item	Part No.	Description	Qty.
1	10-5201	Steel Cage	1
2	22-5065	Cage Floor	1
3	11-3438	Clamp Plate	5
4	508932-000	U-Clamp	2
5	508934-000	Access Bar	1
6	SP-016B102	Pin	1
7	10-2672	Retaining Peg	1
8	10-5206	Control Support	1
9	13-0176	Double Over-centre Valve	1
10	13-2200	Control Valve	1
11	22-5370	Rear Cover	1
12	22-5601	Blanking Plate	1
13	09-1276	Socket (110V)	1
14	22-5543	Control Support Top Plate (Battery & Engine Powered)	1
15	508140-000	RCD	1
16	09-2126	Amber Marker Lamp	2
17	09-1939	Swivel Light	2

GRP BASKET COMPONENTS

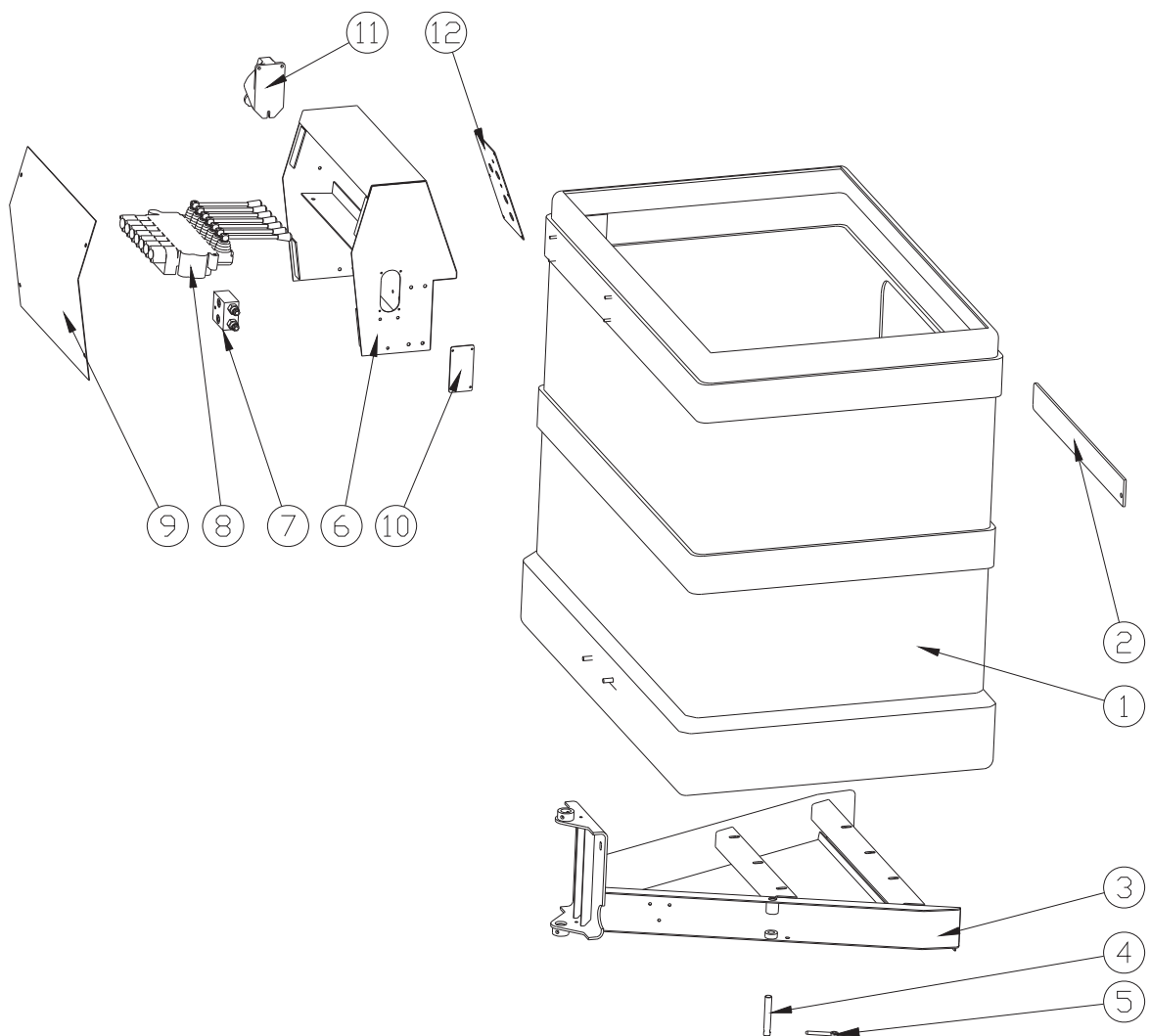

GRP Basket Components			
Item	Part No.	Description	Qty.
1	02-2674	GRP Basket	1
2	22-5603	Access Guard	1
3	10-5317	Basket Support	1
4	SP-016B102	Pin	1
5	10-2672	Retaining Peg	1
6	10-5206	Control Support	1
7	13-0176	Double Overcentre Valve	1
8	13-2200	Control Valve	1
9	22-5370	Rear Cover	1
10	22-5601	Blanking Plate	1
11	09-1276	Socket (110V)	1
11	09-1392	Socket (230V)	1
12	22-5543	Control Support Top Plate (Battery & Engine Powered)	1
12	22-5542	Control Support Top Plate (Mains Powered)	1
12	22-5544	Control Support Top Plate (Mains Powered c/w Generator)	1

OUTRIGGER RAM COMPONENTS

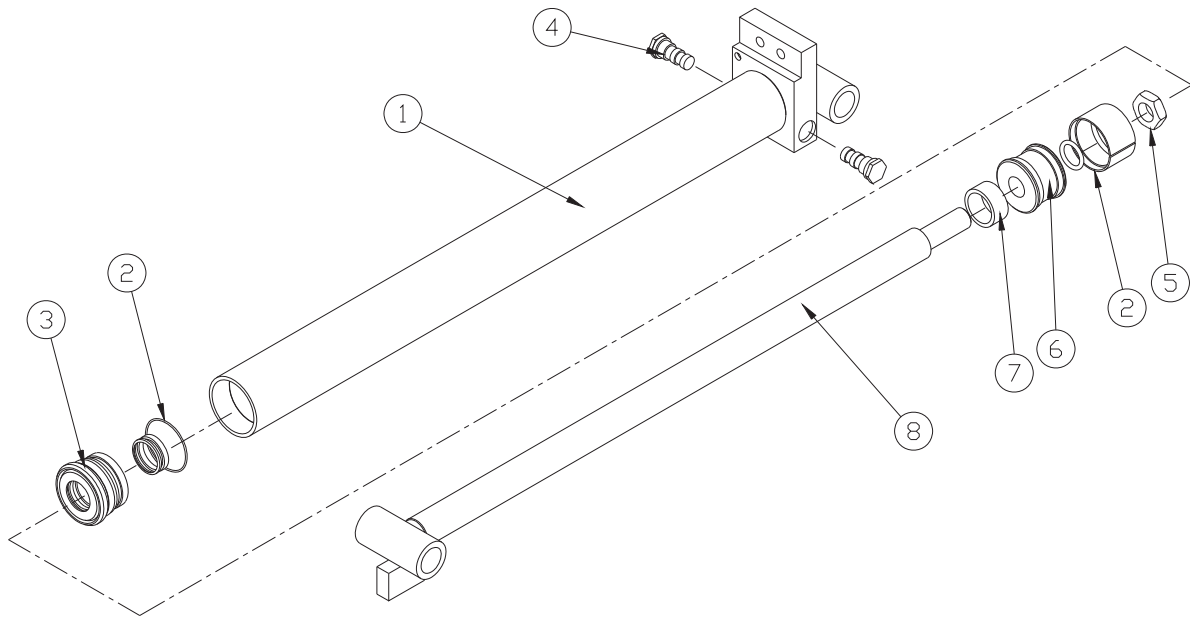

Outrigger Ram - 13-3608			
Item	Part No.	Description	Qty.
1	13-3608-1	Tube Assembly	1
2	13-2351	Seal Kit	1
3	13-1004	Head Bush	1
4	13-0604	PO Check Valve	2
5	13-0973	Locknut	1
6	13-1007	Piston	1
7	SS-0400023	Spacer	1
8	13-3608-2	Rod Assembly	1

BOTTOM RAM COMPONENTS

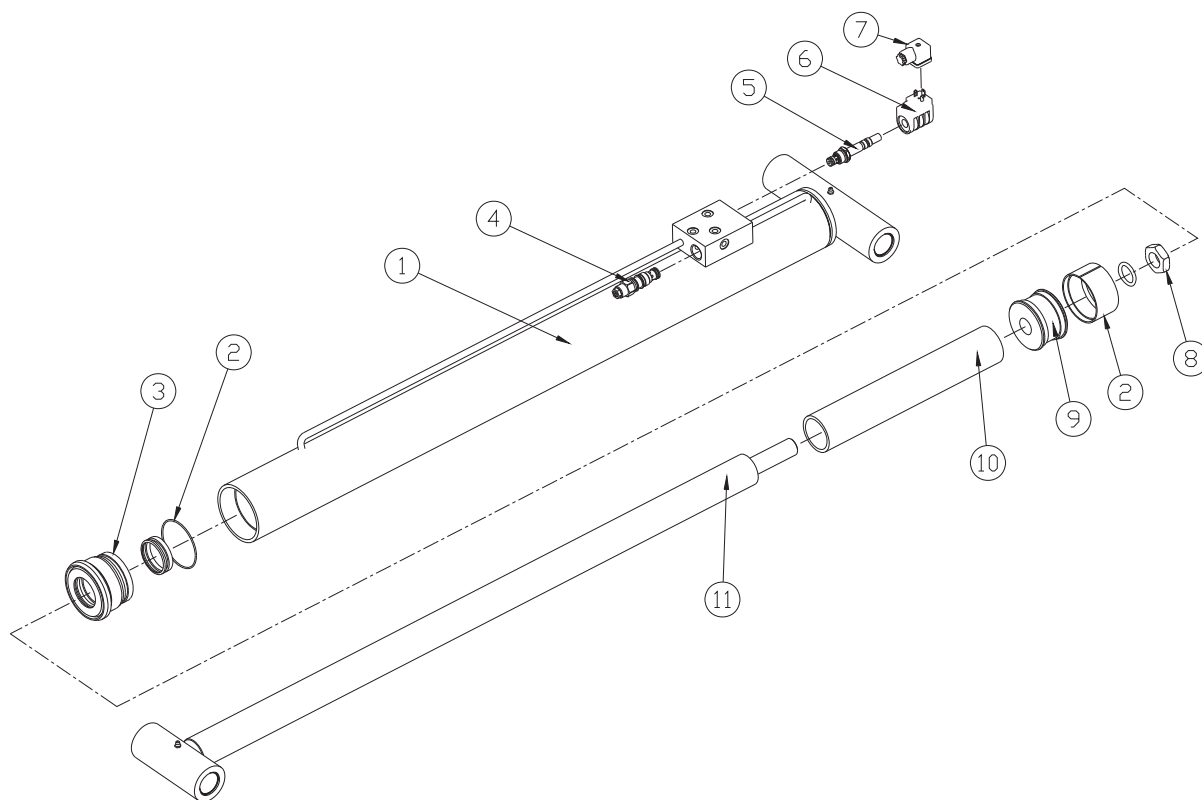

Bottom Ram - 13-3607			
Item	Part No.	Description	Qty.
1	13-3607-1	Tube Assembly	1
2	13-0972	Seal Kit	1
3	13-0968	Head Bush	1
4	13-0392	Over-centre Valve	1
5	13-2474/2	Emergency Lower Valve	1
6	09-2090	Solenoid	1
7	13-2425/77	Hirschmann Connector	1
8	13-0973	Locknut	1
9	13-0971	Piston	1
10	SS-0500343	Spacer	1
11	13-3607-2	Rod Assembly	1

TOP RAM COMPONENTS

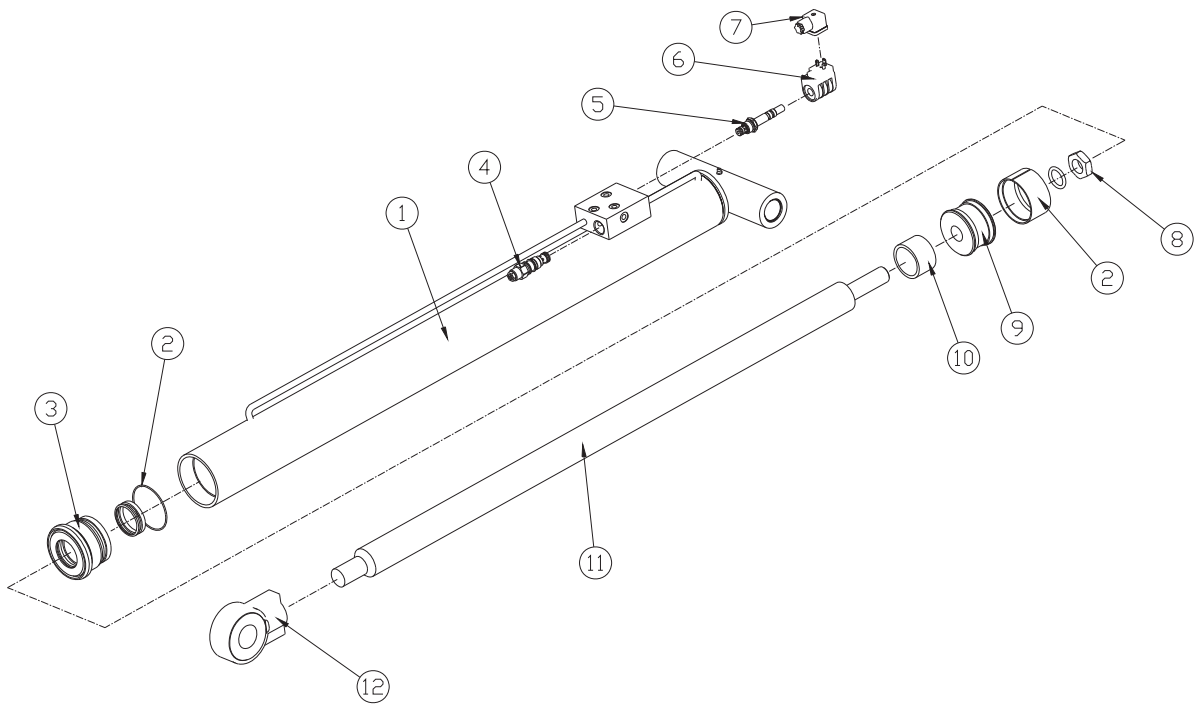

Top Ram - 13-3606			
Item	Part No.	Description	Qty.
1	13-3606-1	Tube Assembly	1
2	13-0972	Seal Kit	1
3	13-0968	Head Bush	1
4	13-0392	Over-centre Valve	1
5	13-2474/2	Emergency Lower Valve	1
6	09-2090	Solenoid	1
7	13-2425/77	Hirschmann Connector	1
8	13-0973	Locknut	1
9	13-0971	Piston	1
10	SS-0500037	Spacer	1
11	13-3606-2	Rod	1
12	13-3606-3	Bearing	1

MASTER RAM COMPONENTS

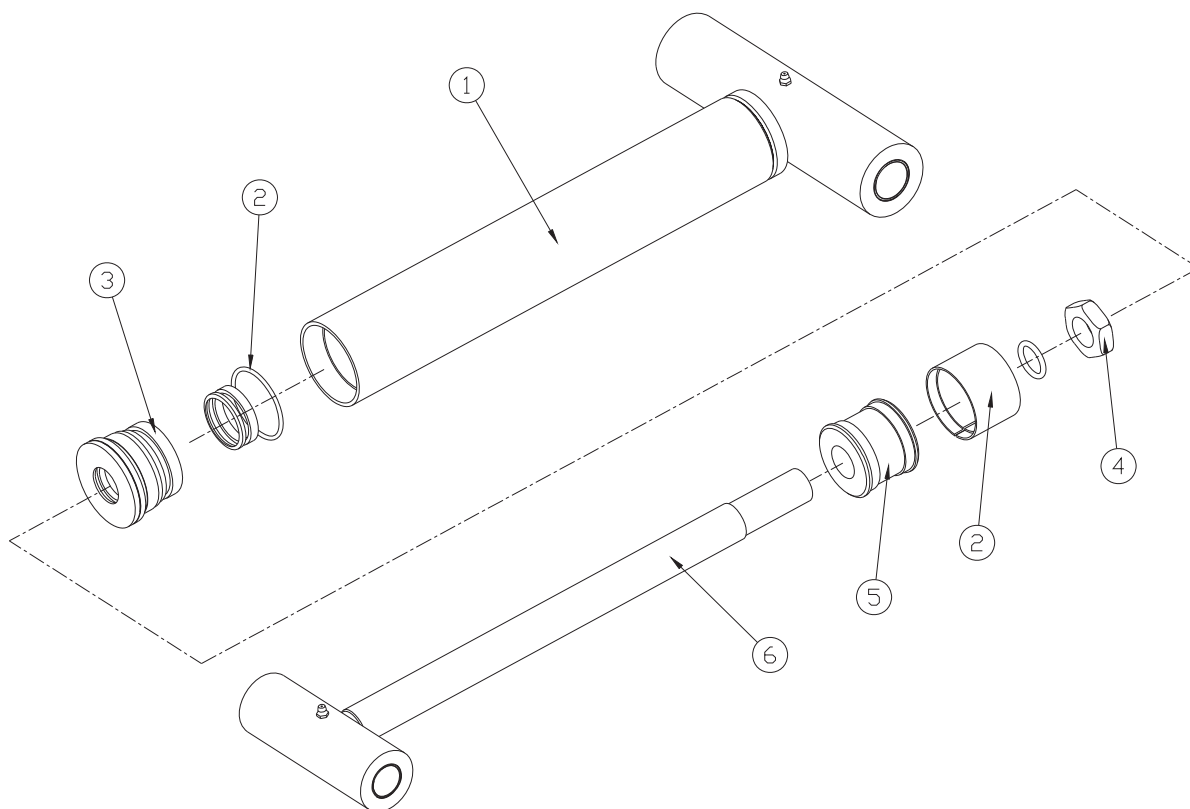

Master Ram - 13-3604			
Item	Part No.	Description	Qty.
1	13-3604-1	Tube Assembly	1
2	13-3603-3	Seal Kit	1
3	13-1061	Head Bush	1
4	13-0973	Locknut	1
5	13-1064	Piston	1
6	13-3604-2	Rod Assembly	1

TELESCOPE RAM COMPONENTS

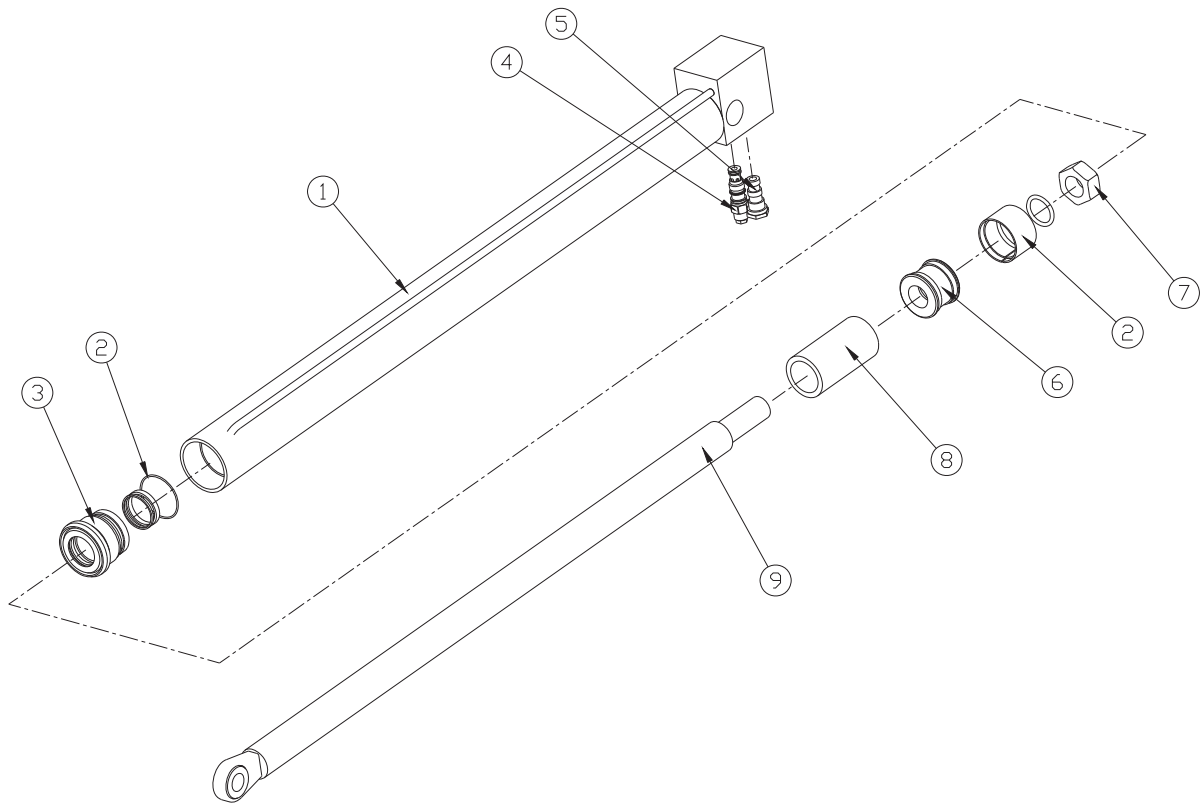

Telescope Ram - 13-3605			
Item	Part No.	Description	Qty.
1	13-3605-1	Tube Assembly	1
2	13-3605-3	Seal Kit	1
3	13-3605-4	Head Bush	1
4	13-0472	Over-centre Valve	1
5	13-0659	PO Check Valve	1
6	13-3605-5	Piston	1
7	13-3605-6	Locknut	1
8	13-3605-7	Spacer	1
9	13-3605-2	Rod Assembly	1

LEVELLING RAM COMPONENTS

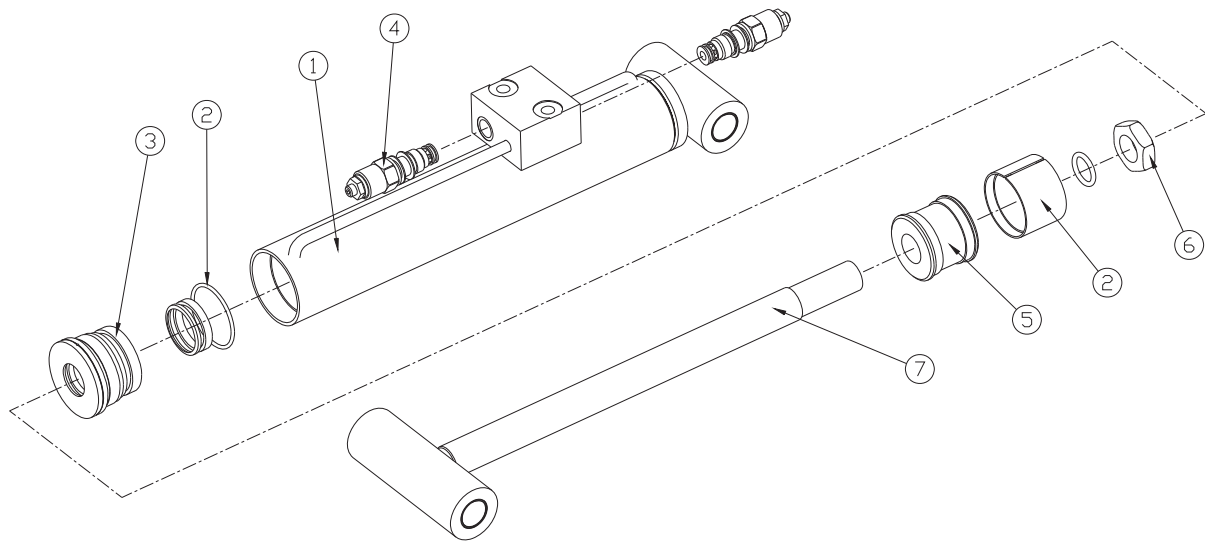

Levelling Ram - 13-3603			
Item	Part No.	Description	Qty.
1	13-3603-1	Tube Assembly	1
2	13-3603-3	Seal Kit	1
3	13-1061	Head Bush	1
4	13-2489	Over-centre Valve	2
5	13-1064	Piston	1
6	13-0973	Locknut	1
7	13-3603-2	Rod Assembly	1

DROPSNOSE RAM COMPONENTS

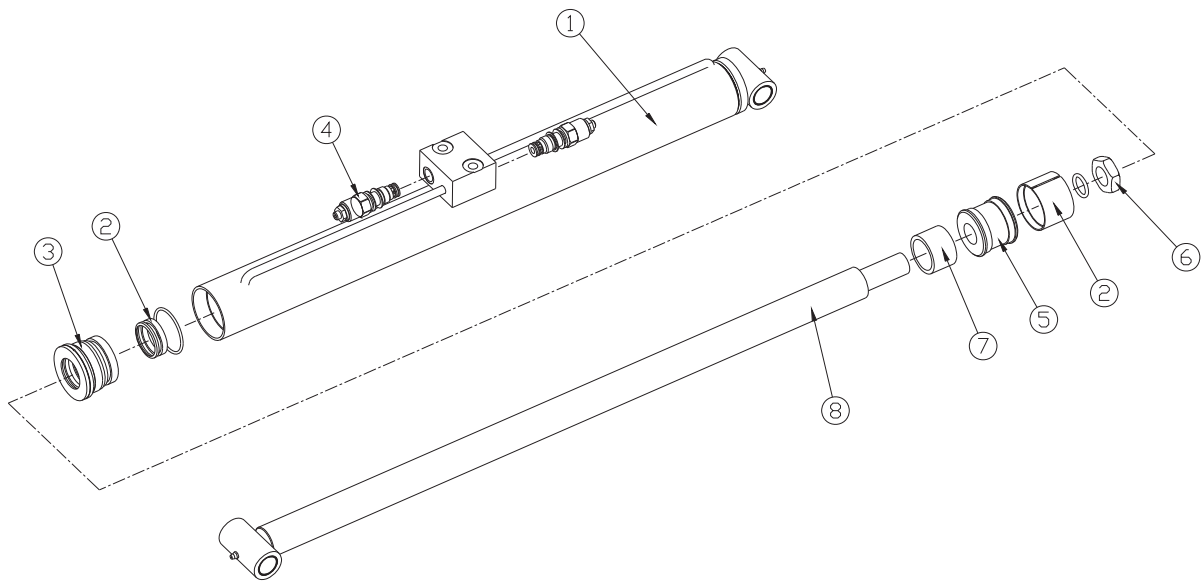

Drop-nose Ram - 13-3602			
Item	Part No.	Description	Qty.
1	13-3602-1	Tube Assembly	1
2	13-3603-3	Seal Kit	1
3	13-1061	Head Bush	1
4	13-2489	Over-centre Valve	2
5	13-1064	Piston	1
6	13-0973	Locknut	1
7	13-3602-3	Spacer	1
8	13-3602-2	Rod Assembly	1

CAGE ROTATION RAM COMPONENTS

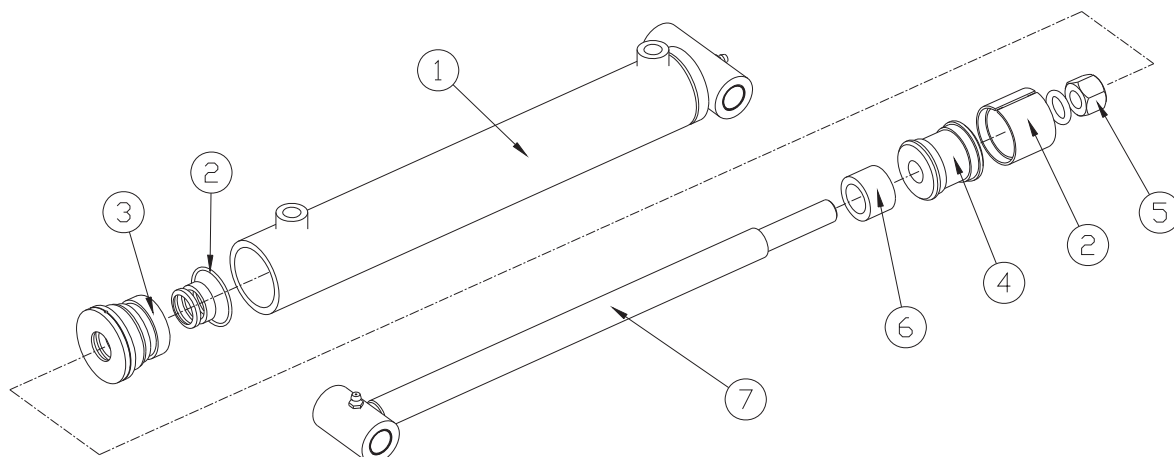

Cage Rotation Ram - 13-2403			
Item	Part No.	Description	Qty.
1	13-2403-1	Tube Assembly	1
2	13-0993	Seal Kit	1
3	13-0988	Head Bush	1
4	13-0992	Piston	1
5	13-0994	Locknut	1
6	SS-0200020	Spacer	1
7	13-2403-2	Rod Assembly	1

Electrical Parts Kit 02-2639			
Location	Part No.	Description	Qty.
Control Box	TA0001-2639	Control Box Lable	1
Control Box	TA0002-2639	Top Hat DIN Rail	0.3
Control Box	TA0003-2639	SN04062K Weiland Safety Relay	2
Control Box	TA0004-2639	4 AMP 1 Pole MCB Type C	2
Control Box	TA0005-2639	Interface Relay Type P16	10
Control Box	TA0006-2639	Entrelec 2.5mm Double Deck ISO Terminals	28
Control Box	TA0007-2639	End Plate for TA0006	1
Control Box	TA0008-2639	IN4001 Diode	4
Cage	TA0009-2639	20 Way Connection Strip for P16	2
	TA0010-2639	6A 250v AC with 391-8350-729 Actuator	1
Control Box	TA0011-2639	M20 Gland (Black)	1
Hour Meter	TA0012-2639	M/C Box PS111165 2 Hole	1
Cage	TA0013-2639	Buzzer	1
Hour Meter	TA0014-2639	PG09 Grey Locknut	2
Control Box & Cage	TA0015-2639	Emergency Stop Button	2
Top Boom	TA0016-2639	Limit Switch	1
	TA0017-2639	PG09 Grey Gland	2
Control Box	TA0018-2639	2 Pos.Stay-put Key	1
	TA0019-2639	Booted Actuator	1
Hour Meter	TA0020-2639	Hour Meter AC	2
	TA0021-2639	3 POSITIVE LONG HANDLE	2
Outriggers	TA0022-2639	Limit Switch 2 N/C	4
	TA0023-2639	16mm Slit Conduit 25M Coil	1
Control Box & Cage	TA0024-2639	40mm Mushroom Head Green Spring Button	2
	TA0025-2639	Turret Head	4
	TA0026-2639	4 Pin Male M12 Chassis Plug with M20 Thread	6
Control Box & Cage	TA0027-2639	40mm Mushroom Head Black Spring Button	1
Control Box & Cage	TA0028-2639	1 N/O Contact	5
Control Box & Cage	TA0029-2639	2 N/O Contact	3
Control Box & Cage	TA0030-2639	2 x N/C Contact	2
Control Box & Cage	TA0031-2639	N/O ANS N/C CONTACTS	1
Control Box & Cage	TA0032-2639	10 Way Jumper Bar	3
Control Box & Cage	TA0033-2639	Red L.E.D.	2
Control Box & Cage	TA0034-2639	Green L.E.D with Panel Mount Fitting	5
	TA0035-2639	M12 ST FM 4 POLE 5M PUR	4
	TA0036-2639	M12 5M BRAD H.LEAD 90 DEGREE	1
	TA0037-2639	Terminal Devider	11
Control Box & Cage	TA0038-2639	N/C Contact Block	1
Cage	TA0039-2639	16mm Black Nylon Locknut	12
Cage	TA0040-2639	M16 Gland Black	12
Cage	TA0041-2639	Cable Gland	2
Cage	TA0042-2639	Locknut	2

Electrical Parts Kit 02-2639 (Cont)			
Location	Part No.	Description	Qty.
	TA0047-2639	KA132000B9 Valve Plug	5
Control Box	TA0050-2639	ABS Machined Enclosure	1
	TA0054-2639	Blanking Plug	1
	TA0055-2639	2 Position Key (spring to off)	1
Cage	TA0056-2639	Key Selector Switch (3 Position)	1
Cage	TA0057-2639	Green Push Button Switch	1
	TA0058-2639	12 Way Terminal Block 15 AMP	2
	TA0059-2639	1 N/O Add-on Contact	2
Cage	TA0060-2639	Cage Control Plate	1
	TA0064-2639	Battery Power Conectors	2
	TA0065-2639	ETU 35 / 8 Non ROHS Compliant	4

TL49J Basic Fittings Kit (All Specifications)		
Part N°	Description	QTY.
12-1008	1/4" BSP Male x 7/16" JIC Male Straight Adaptor	29
12-1007	3/8" BSP Male x 7/16" JIC Male Straight Adaptor	41
12-9005	3/8" BSP Male x 7/16" JIC Male Straight 25thou restrictor	4
12-9004	3/8" BSP Male x 7/16" JIC Male Straight 40thou restrictor	2
12-1013	3/8" BSP Male x 9/16" JIC Male Straight Adaptor	10
12-1017	1/2" BSP Male x 9/16" JIC Male Straight Adaptor	3
12-1869	1/4" BSP Male x 7/16" JIC Male Positional Elbow	6
12-1110	7/16" JIC Equal Tee Female-on-Run.	6
12-1501	1/2" Dowty Washer	6
12-1502	3/8" Dowty Washer	64
12-1507	1/4" Dowty Washer	45
12-1511	1/8" Dowty Washer	1
12-1867	9/16" JIC Male/Female Elbow	1
12-2001	1/2" BSP Male Plug	1
12-2003	3/8" BSP Male Plug	6
12-2002	1/8" BSP Male Plug	1
12-0927	9/16" UNF Male x 9/16" JIC Male Straight Adaptor	1
12-9007	9/16" UNF Male Plug	1
5063701	7/16" (-4) JIC Female Cap	1
12-0916	1/4" BSP Male x 1/4" BSP Female Straight Adaptor	1
12-1001	3/8" BSP Male x 1/4" BSP Male Straight Adaptor	6
12-1502	3/8" Dowty Washer	6
12-1879	1/4" BSP Female x 1/4" BSP Female Compact 90 deg Elbow	1

Illustrated Parts List

Part Number	N° Off	Location	Hose Size	End Fittings		Length
				End 'A'	End 'B'	
G1	2	Outrigger Valve to Outrigger Ram 1	1/4 R7	7/16 JIC Female Straight	7/16 JIC Female 135 deg	3000
G2	2	Outrigger Valve to Outrigger Ram 2	1/4 R7	7/16 JIC Female Straight	7/16 JIC Female 135 deg	3100
G3	2	Outrigger Valve to Outrigger Ram 3	1/4 R7	7/16 JIC Female Straight	7/16 JIC Female 135 deg	1800
G4	2	Outrigger Valve to Outrigger Ram 4	1/4 R7	7/16 JIC Female Straight	7/16 JIC Female 135 deg	1700
G5	1	Outrigger Valve to Manifold P	1/4 R7	7/16 JIC Female Straight	7/16 JIC Female Straight	1700
G6	1	Outrigger Valve to Tank Manifold	1/4 R7	7/16 JIC Female Straight	7/16 JIC Female Straight	1700
G7	2	Base Valve to Bottom Ram	1/4 R7	7/16 JIC Female Straight	7/16 JIC Female Straight	1500
G8	1	Bottom Ram Emergency Lower	1/4 R7	7/16 JIC Female Straight	7/16 JIC Female Straight	1530
G9	2	Base Valve to Top Ram	1/4 R7	7/16 JIC Female Straight	7/16 JIC Female Straight	6700
G10	1	Top Ram Emergency Lower	1/4 R7	7/16 JIC Female Straight	7/16 JIC Female Straight	6800
G11	2	Base Valve to Telescope Ram	1/4 R7	7/16 JIC Female Straight	7/16 JIC Female Straight	6900
G12	1	Telescope Ram Drain	1/4 R7	7/16 JIC Female Straight	7/16 JIC Female Straight	6900
G13	1	Base Valve P to Manifold GP	3/8 702	9/16 JIC Female Straight	9/16 JIC Female Straight	1200
G14	2	Base Valve to Manifold Slew Tee	1/4 R7	7/16 JIC Female Straight	7/16 JIC Female 90 deg	1000
G15	1	Hand-pump to Manifold HP1	1/4 R7	7/16 JIC Female 90 deg	7/16 JIC Female Straight	700
G16	2	Slew Motor to Manifold SLA/SLB	1/4 R7	7/16 JIC Female 90 deg	7/16 JIC Female 90 deg	1200
G17	2	Base Valve to Drop-nose Ram	1/4 R7	7/16 JIC Female Straight	7/16 JIC Female Straight	18200
G18	2	Basket Valve to Bottom Ram	1/4 R7	7/16 JIC Female Straight	7/16 JIC Female Straight	17800
G19	2	Basket Valve to Manifold Slew Tee	1/4 R7	7/16 JIC Female Straight	7/16 JIC Female Straight	18700
G20	1	Basket Valve P to Manifold CP	3/8 702	9/16 JIC Female Straight	9/16 JIC Female Straight	18700
G21	1	Tank Manifold to Manifold T	3/8 702	9/16 JIC Female Straight	9/16 JIC Female Straight	600
G22	1	Tank Manifold to Base Valve T	3/8 702	9/16 JIC Female Straight	9/16 JIC Female Straight	370
G23	1	Pump to Manifold P	3/8 702	9/16 JIC Female Straight	9/16 JIC Female 90 deg	400
G24	1	Tank Manifold to Filter	3/8 702	9/16 JIC Female Straight	9/16 JIC Female Straight	1000

Part Number	N° Off	Location	Hose Size	End Fittings		Length
				End 'A'	End 'B'	
G26	1	Basket Valve to Tank Manifold	³ / ₈ 702	9/16 JIC Female Straight	9/16 JIC Female Straight	18300
G27	2	Basket Valve to Top Ram	1/4 R7	7/16 JIC Female Straight	7/16 JIC Female Straight	12700
G28	2	Basket Valve to Telescope Ram	1/4 R7	7/16 JIC Female Straight	7/16 JIC Female Straight	12000
G29	2	Master Ram to DOC Valve	1/4 R7	7/16 JIC Female Straight	7/16 JIC Female Straight	12100
G30	1	Basket Valve to Slewing Ram	1/4 R7	7/16 JIC Female Straight	7/16 JIC Female 90 deg	2300
G31	1	Basket Valve to Slewing Ram	1/4 R7	7/16 JIC Female Straight	7/16 JIC Female 90 deg	2200
G32	2	Basket Valve to Drop-nose Ram	1/4 R7	7/16 JIC Female Straight	7/16 JIC Female 90 deg	4100
G33	2	DOC Valve to Basket Levelling Ram	1/4 R7	7/16 JIC Female Straight	7/16 JIC Female 90 deg	3900
G34	2	Basket Valve to DOC Valve	1/4 R7	7/16 JIC Female Straight	7/16 JIC Female 90 deg	600
H1	1	Pump to Manifold	1/4 R7	9/16 JIC Female Straight	7/16 JIC Female 90 deg	300
H2	1	Engine Pump to Manifold Tee	1/4 R7	9/16 JIC Female Straight	9/16 JIC Female 90 deg	1200
H3	1	Engine Pump to Tank Suction Port	¹ / ₂ R1AT	1/2 BSP Female Straight	1/2 BSP Female 90 deg	1940
H14	1	Pressure Relief V/V to Tank	1/4 R7	9/16 JIC Female 90 deg	9/16 JIC Female Straight	1060

TL49J Friction Drive kit 13-3670

Linden Part No	Description	Qty
H4	1/4 1SN 9/16 JIC F STR X 9/16 JIC F 90 200	1
H5	1/4 1SN 9/16 JIC F 45 X 9/16 F 90 215	1
H6	1/4 1SN 9/16 JIC F STR X 9/16 JIC F 90 190	1
H7	1/4 1SN 9/16 JIC F 45 X 9/16 F 90 250	1
H8	1/4 1SN 9/16 JIC F 45 X 9/16 F 90 1525	2
H9	1/4 1SN 9/16 JIC F 45 X 9/16 F 90 1650	2
H10	3/8 1SN 9/16 JIC F STR X 9/16 JIC F 45 3275	1
H11	3/8 1SN 9/16 JIC F STR X 9/16 JIC F 90 3275	1
H12	1/4 1SN 9/16 JIC F STR X 9/16 JIC F STR 910	2
H13	1/4 1SN 9/16 JIC F STR X 9/16 JIC F STR 1220	1

TL49J Battery/Mains Power

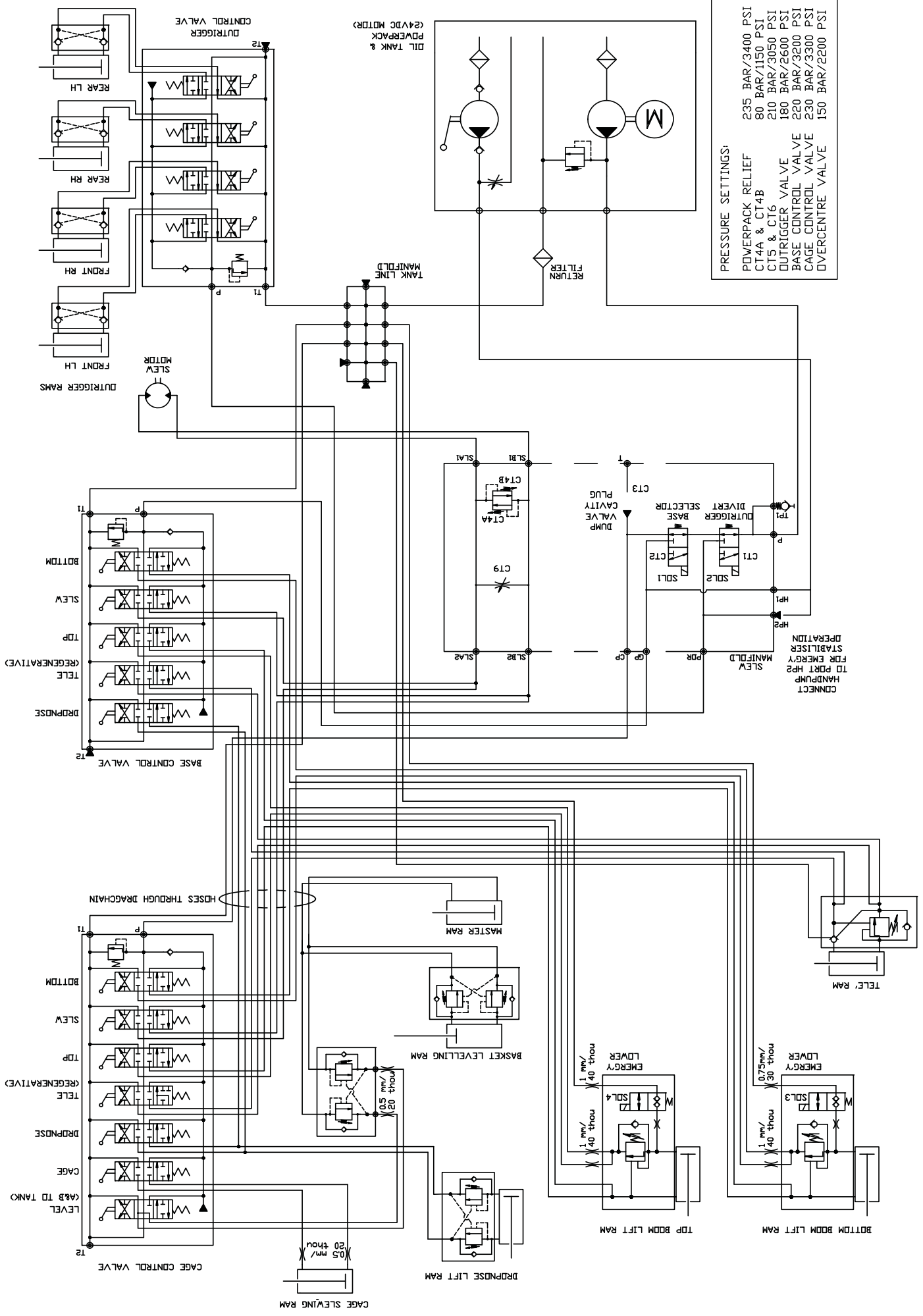

PRESSURE SETTINGS:
 POWERPACK RELIEF 235 BAR/3400 PSI
 CT4A & CT4B 80 BAR/1150 PSI
 CT5 & CT6 210 BAR/3050 PSI
 DUTRIGGER VALVE 180 BAR/2600 PSI
 BASE CONTROL VALVE 220 BAR/3200 PSI
 CAGE CONTROL VALVE 230 BAR/3300 PSI
 DIVERCENTRE VALVE 150 BAR/2200 PSI

TL49J Diesel/Petrol Powered

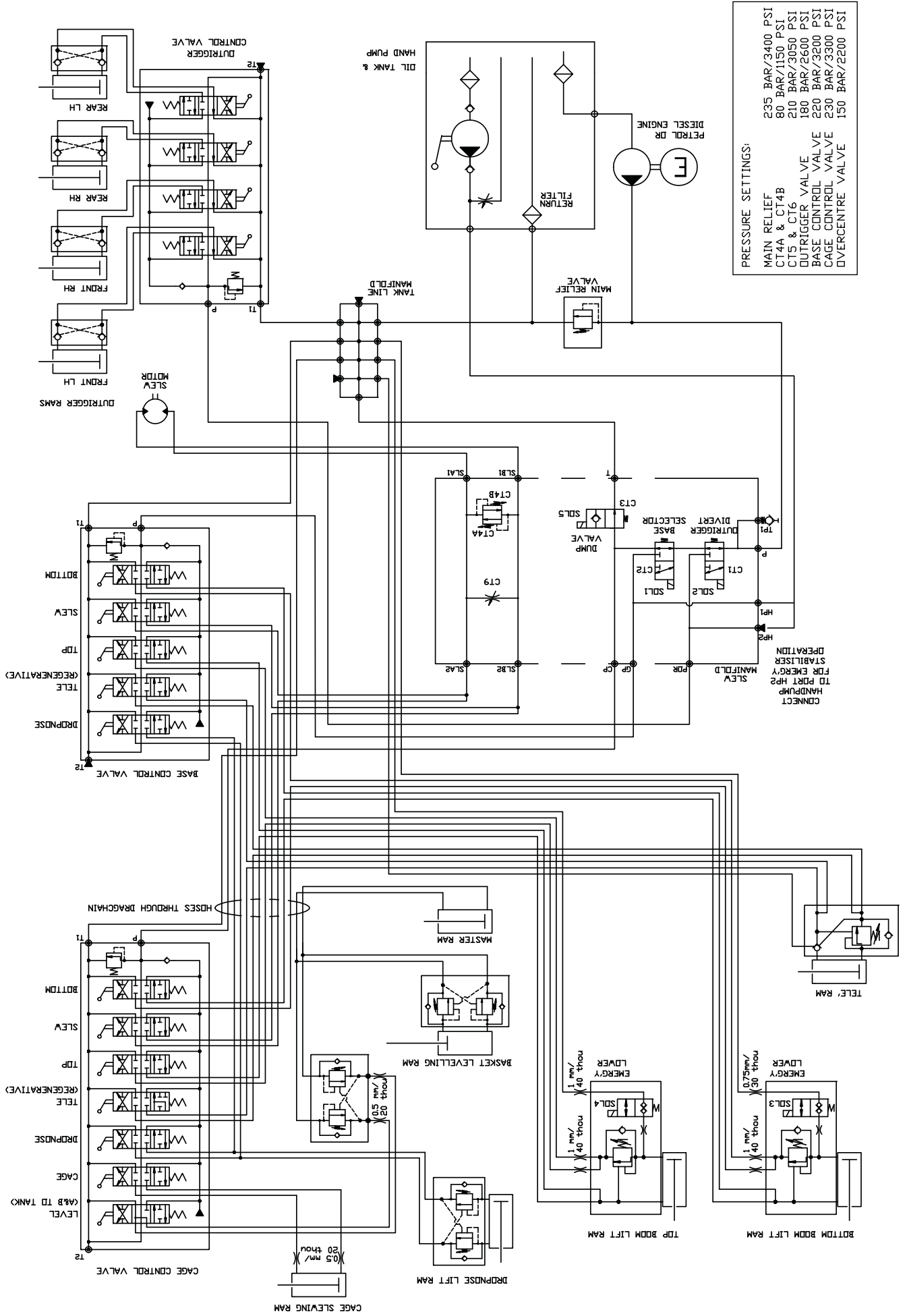

PRESSURE SETTINGS:

MAIN RELIEF	235 BAR/3400 PSI
CT4A & CT4B	80 BAR/1150 PSI
CT5 & CT6	210 BAR/3050 PSI
OUTRIGGER VALVE	180 BAR/2600 PSI
BASE CONTROL VALVE	220 BAR/3200 PSI
CAGE CONTROL VALVE	230 BAR/3300 PSI
DIVERCENTRE VALVE	150 BAR/2200 PSI

TL49J Bi-Fuel Powered

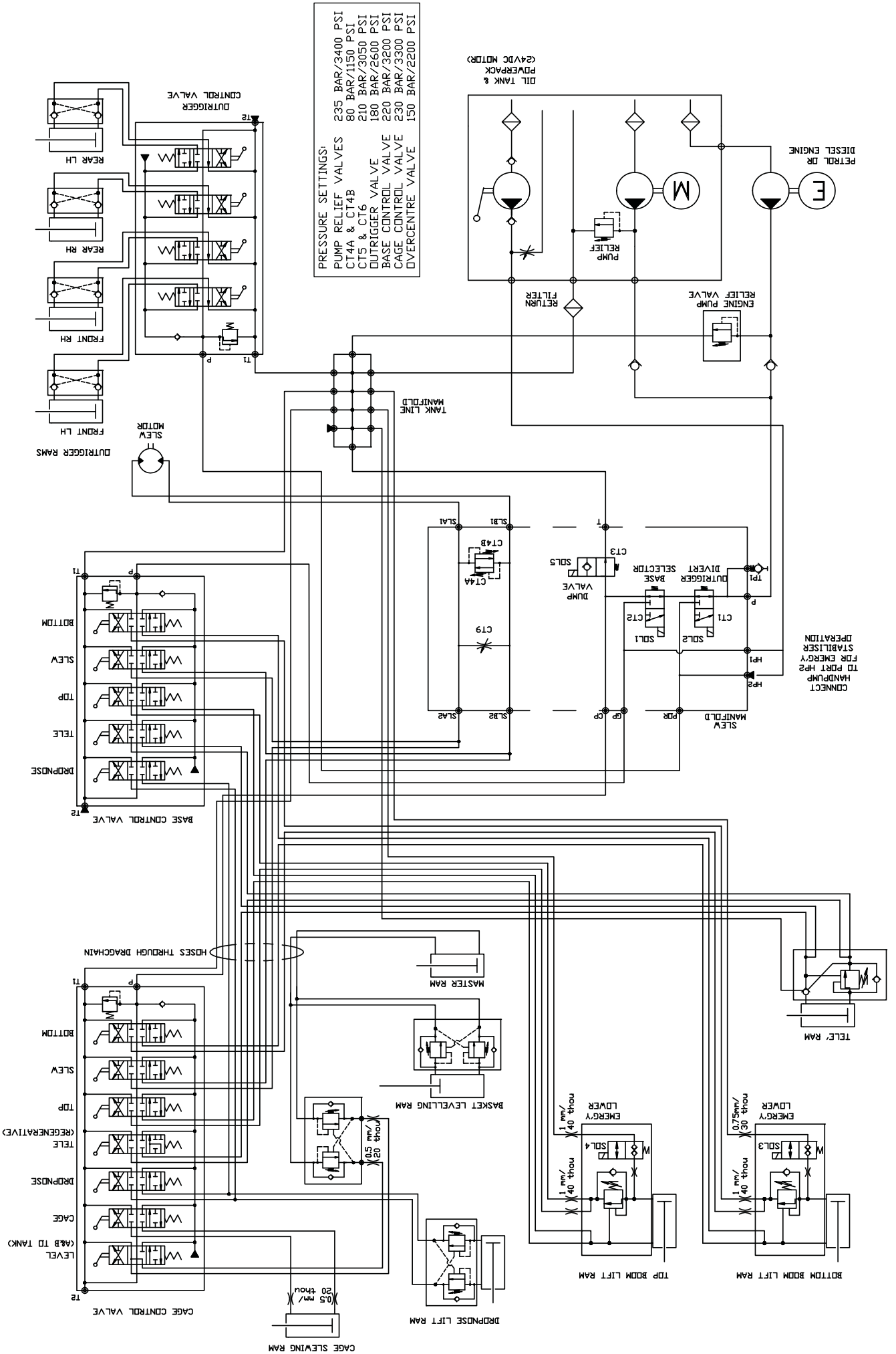

PRESSURE SETTINGS:
 PUMP RELIEF VALVES 235 BAR/3400 PSI
 CT4A & CT4B 80 BAR/1150 PSI
 CT5 & CT6 210 BAR/3050 PSI
 OUTRIGGER VALVE 180 BAR/2600 PSI
 BASE CONTROL VALVE 220 BAR/3200 PSI
 CAGE CONTROL VALVE 230 BAR/3300 PSI
 OVERCENTRE VALVE 150 BAR/2200 PSI

PETROL DR
 DIESEL ENGINE

DIL TANK &
 POWERPACK
 (24VDC MOTOR)

CONNECT
 HANDPUMP
 TID POINT
 FOR ENERGY
 STABILISER
 OPERATION

TL49J Bi-Fuel with friction drive option

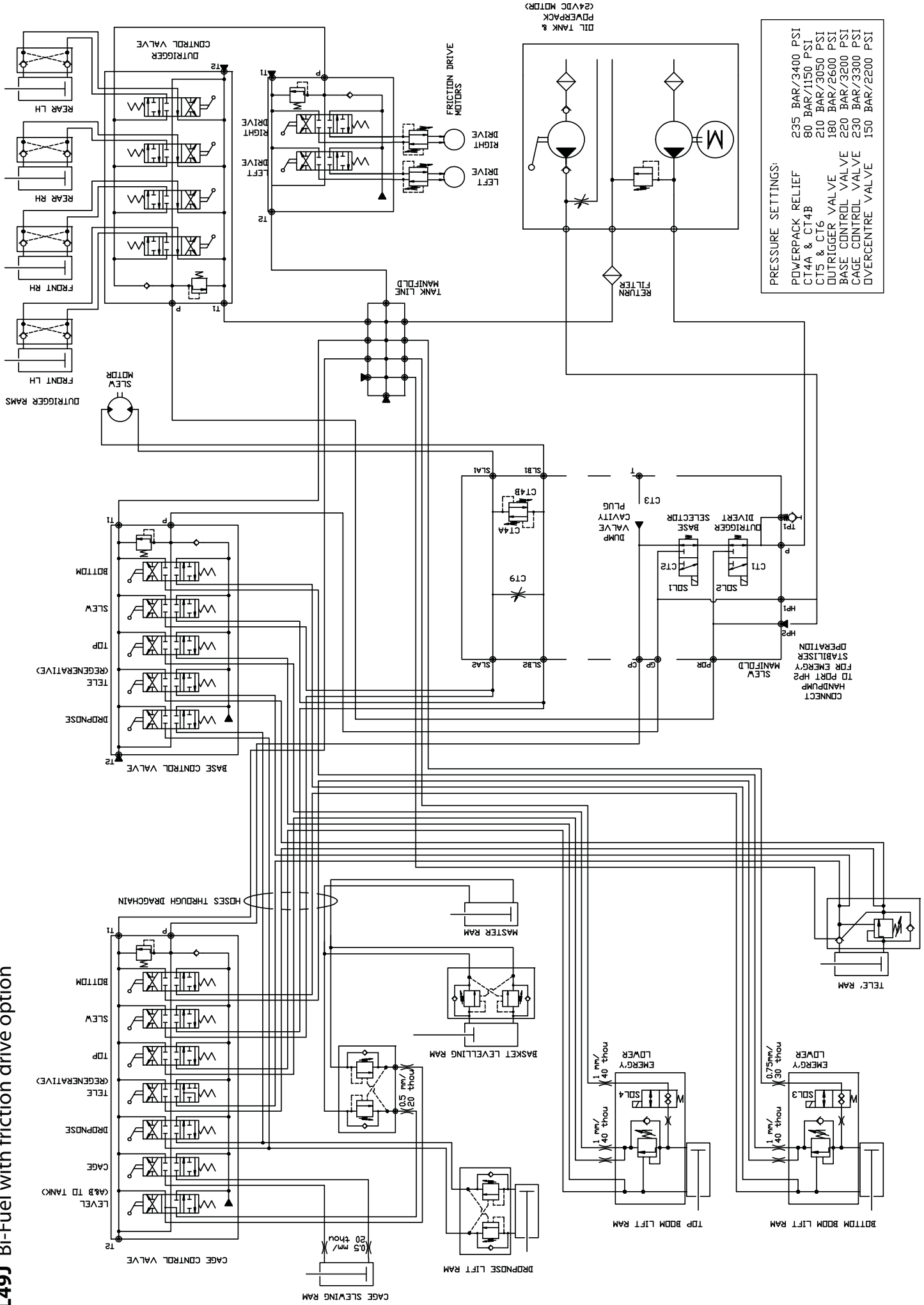

PRESSURE SETTINGS:

POWERPACK RELIEF	235 BAR/3400 PSI
CT4A & CT4B	80 BAR/1150 PSI
CT5 & CT6	210 BAR/3050 PSI
OUTRIGGER VALVE	180 BAR/2600 PSI
BASE CONTROL VALVE	220 BAR/3200 PSI
CAGE CONTROL VALVE	230 BAR/3300 PSI
OVERCENTRE VALVE	150 BAR/2200 PSI

CONNECT
HANDPUMP
TO PORT HP2
FOR ENERGY
STABILISER
OPERATION

**Local Distributor / Lokaler Vertiebs­händler / Distributeur local
El Distribuidor local / Il Distributore locale**

**EUROPE, MIDDLE EAST
AFRICA & ASIA**

PHONE: +44 (0) 845 1550 057
FAX: +44 (0) 845 1557 756

NORTH & SOUTH AMERICA

PHONE: +1 785 989 3000
TOLL FREE: +1 800 225 0317
FAX: +1 785 989 3070

AUSTRALIA

PHONE: +61 2 9725 4000
FAX: +61 2 9609 3057

NEW ZEALAND

PHONE: +64 6 3689 168
FAX: +64 6 3689 164

 **snorkel**
www.snorkellifts.com